

Product Brochure For B007

Metal Cutting Band Saw - Swivel Vice - BS-7

Mitre Cuts Up To 45° & Includes Hydraulic Downfeed Control
300 x 180mm (W x H) Rectangle Capacity

On Sale

Ex GST	Inc GST
\$1,526.00	\$1,754.90
\$1,326.09	\$1,525.00



ORDER CODE:	B007
MODEL:	BS-7
Operation Type:	Fixed Head
Round @ 90° (mm):	180
Round @ 45° (mm):	110
Round @ 60° (mm):	~
Square @ 90° (mm):	180
Square @ 45° (mm):	110
Square @ 60° (mm):	~
Rectangle (W x H) @ 90° (mm):	300 x 180
Rectangle (W x H) @ 45° (mm):	110 x 180
Rectangle (W x H) @ 60° (mm):	~
Coolant System:	Yes
Table Working Height (mm):	550
Cutting Head Beam Type:	Manual
Cutting Head Beam Return:	Manual Return
Cutting Head Down Feed Control:	Adjustable Hydraulic
Vice Clamping Fixture:	Manual
Bundle Cutting Fixture:	~
Blade Steps / Speeds (M/Min):	34, 41, 59, 98
Blade Size (L x W x T) (mm):	2362 x 19 x 0.8
Motor Power (kW / hp):	0.75 / 1
Voltage / Amperage (V / amp):	240 / 10
Nett Weight (kg):	166

Description

Looking for a 7" metal bandsaw that outshines the competition in quality and reliability? Our Metalmaster BS-7 is the perfect solution. While our competitors may offer similar-looking products at a lower price, our bandsaw's superior craftsmanship and our company's 90-year legacy in the industry set us apart. We have been delivering unmatched quality and durability for decades, ensuring that you invest in machinery that is built to last.

Features

- 300 x 180mm (W x H) rectangular capacity @ 90 Degrees
- Adjustable hydraulic cutting feed rate for multiple applications
- Mitre cuts to 45° using calibrated vice
- Built-in coolant system with flow control valve
- Automatic electric cut-out switch stops machine when cut is complete
- Roller bearing blade guides provides accurate cutting
- 4 cutting speeds via step pulleys (34-41-59-98mpm)
- Adjustable length stop for repetition cutting
- Portable - on wheels for ease of use
- Vertical cutting table included
- Heavy-duty 0.75kW / 1hp 240V motor

Includes

- 1 x blade
- Vertical cutting table

Product Brochure For B007

Specific Features



Blade Guide with Cleaning Brush



Adjustable Blade Roller Guides



Hydraulic Ram For Down Feed Control



Micro Cut Switch



Length Stop



Main Switch and Coolant Pump Switch



Vice Graduations



Swivel Vice With Handle Wheel



Vice At 90 Degrees



Vice at 45 Degree



Blade Cover Open



Blade Tension Adjustment Handle



Coolant Nozzle

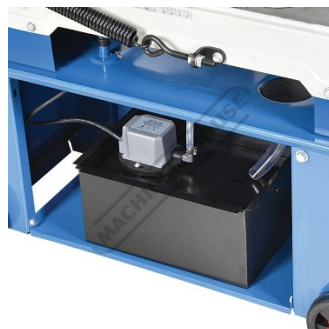

Coolant Tank



Heavy Duty 1HP 240V Motor



4 Speed Belt Drive System with Safety Micro Switch

Product Brochure For B007



Vertical Cutting Table



Vertical Cutting Table Fitted



Vertical Cutting Table Rear View



Vertical Cutting Table Front View



Vertical Cutting Table Parts



Rear View Fully Raised



Rear View



Left View



Left View Head Fully Down



Right View



Front View



Front View Arm Fully Down

Product Brochure For B007

Recommended Accessories

B210

Metal Band Saw Blade - 6TPI
Carbon, Blade - 2362 x 19 x
0.80mm



B212

Metal Band Saw Blade - 8TPI
Carbon, Blade - 2362 x 19 x
0.80mm



B214

Metal Band Saw Blade - 10TPI
Carbon, Blade - 2362 x 19 x
0.80mm



B216

Metal Band Saw Blade - 14TPI
Carbon, Blade - 2362 x 19 x
0.80mm



B400

Metal Band Saw Blade - 4-6TPI
Bi-Metal, Blade - 2362 x 19 x
0.80mm



B404

Metal Band Saw Blade -
6-10TPI Bi-Metal, Blade - 2362 x
19 x 0.80mm



B408

Metal Band Saw Blade -
10-14TPI Bi-Metal, Blade - 2362
x 19 x 0.80mm



S091

Soluble Metal Cutting Fluid - 20
Litre



Product Brochure For B007

S090A
Soluble Metal Cutting Fluid - 1 Litre



S090
Soluble Metal Cutting Fluid - 5 Litre



S076
Cutting Tool Lubricant Fluid - 500ml



S077
Drilling, Tapping & Cutting Tool Lubricant Spray - 400g



S074
Cutting Tool Lubricant Paste - 500g



L300
Magnetic Swarf Remover



M9991
Magnetic Floor Sweeper



L812
Roller Conveyor



L816
Roller Conveyor Stand



W343A
Roller Stand



M800
Rubber Mat - Anti-Fatigue



M805
Rubber Mat - Anti-Fatigue

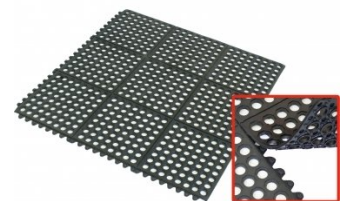

Product Brochure For B007

O043
Rust & Corrosion Preventive



O042
General Purpose Lubricant & Corrosion Inhibitor



O044
Rust & Corrosion Preventive

