

Product Brochure For B142

Semi Automatic Double Column & Swivel Head Band Saw - BMSY-810-CGH

910 x 750mm (W x H) Rectangle Capacity

On Sale

Ex GST

Inc GST

\$71,920.00

\$82,708.00

\$71,000.00

\$81,650.00



ORDER CODE:	B142
MODEL:	BMSY-810-CGH
Operation Type:	Swivel Head & Semi - Automatic
Round @ 90° (mm):	810
Round @ 45° (mm):	555
Round @ 60° (mm):	320
Square @ 90° (mm):	770
Square @ 45° (mm):	555
Square @ 60° (mm):	310
Rectangle (W x H) @ 90° (mm):	910 x 750
Rectangle (W x H) @ 45° (mm):	600 x 750
Rectangle (W x H) @ 60° (mm):	360 x 750
Coolant System:	Yes
Table Working Height (mm):	725
Cutting Head Beam Type:	Semi-Automatic
Cutting Head Beam Return:	Auto-Hydraulic Return
Cutting Head Down Feed Control:	Adjustable Hydraulic
Vice Clamping Fixture:	Automatic-Hydraulic
Bundle Cutting Fixture:	Optional
Blade Steps / Speeds (M/Min):	Variable 20-100
Blade Size (L x W x T) (mm):	8450 x 41 x 1.3
Motor Power (kW / hp):	4 / 5.5
Voltage / Amperage (V / amp):	415
Nett Weight (kg):	4050



Description

Manufactured in Turkey

BMSY-810-CGH SWIVEL HEAD, DOUBLE COLUMN, METAL CUTTING BAND SAW (415V)

Features

- Swivel head for mitre cutting up to 60°
- 2° blade incline for improved cutting
- Inverter variable blade speed control
- Material height sensor for beam to rapid down and start cut feed rate when reached material
- Digital readout display for accurate mitre cutting
- Head mitre hydraulic brake locking system
- Linear guide ways for improved accuracy
- 600mm high vice jaws for increased clamping area
- Auto optical material height adjustment
- Sensitivity cutting pressure dial
- Blade cover safety interlock switches
- SITI industrial duty gearbox drive
- SAP coolant pump system
- Saw blade cleaning brush

Includes

- Laser liner material pointer
- Hydraulic material top clamp
- Hydraulic blade tension device

Optional Accessories

- Motorised in/out feed roller conveyor system

Product Brochure For B142

Specific Features



Head Fully Down



Swivel Head at 60 Degrees



Swivel Head at 60 Degrees Side View



Mitre Cutting Digital Readout Display



Pressure-Sensitivity Feed Controls



Control Panel



Includes Hydraulic Material Top Clamp



Includes Laser Line Pointer

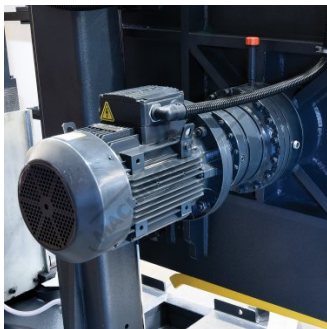

Industrial Gearbox Drive

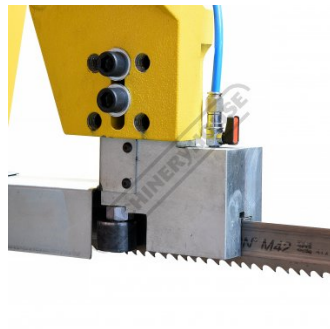

Carbide Blade Guides with Rollers



Blade Guard Safety Micro Switch



Rear Material In Feed Rollers

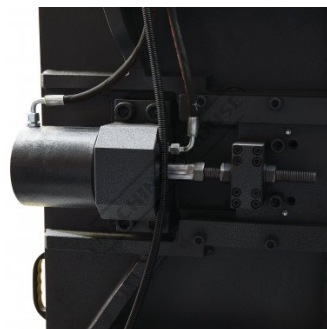

Hydraulic Blade Tension



Blade Cleaning Brush

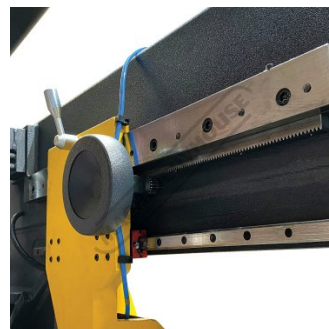

Blade Guide Adjustment Hand Wheel

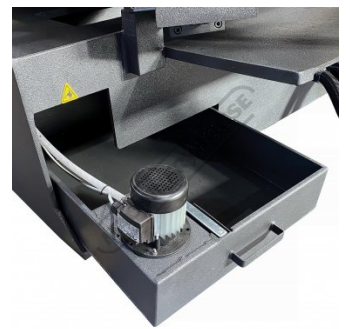

Coolant Pump-Tank Reservoir

Product Brochure For B142

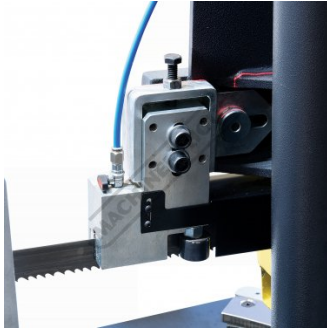

Blade Coolant Flow

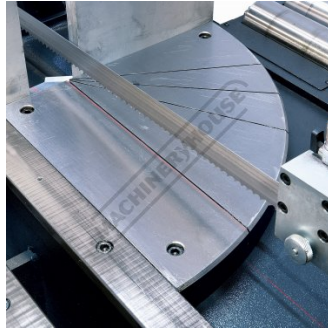

Laser Guide Cut Line



Hydraulic Vice



Hydraulic Vice Closed



Hydraulic Vice Open



Front Material Roller



Coolant Hose



Rear View

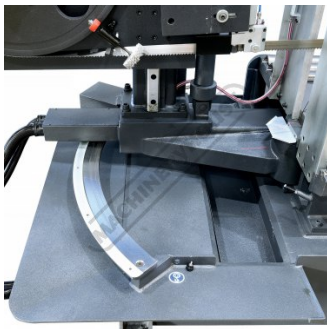

Swivel Head Slide



Linear Guide Ways on Posts



Blade Cover Safety Interlock Switches



Work Light

Product Brochure For B142

Recommended Accessories

B640
Metal Band Saw Blade - 5-8TPI
Bi-Metal, Blade - 8450 x 41 x
1.3mm



W3434
Roller Stand



W3436
Roller Stand - V-Type



W343A
Roller Stand



W343
Roller Stand



S090A
Soluble Metal Cutting Fluid - 1
Litre



S090
Soluble Metal Cutting Fluid - 5
Litres



S076
Cutting Tool Lubricant Fluid -
500ml



Product Brochure For B142

S077

Drilling, Tapping & Cutting Tool
Lubricant Spray - 400g



S074

Cutting Tool Lubricant Paste -
500g



S091

Soluble Metal Cutting Fluid - 20
Litre



L300

Magnetic Swarf Remover



M9991

Magnetic Floor Sweeper



L812

Roller Conveyor



L816

Roller Conveyor Stand



M800

Rubber Mat - Anti-Fatigue



M805

Rubber Mat - Anti-Fatigue

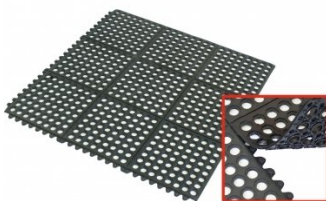

O043

Rust & Corrosion Preventive



O042

General Purpose Lubricant &
Corrosion Inhibitor



O044

Rust & Corrosion Preventive

