

Product Brochure For C414

## Industrial Caster Wheels - CW150S

Ø150mm Wheels  
2 x Swivel/Brake



**On Sale**

Ex GST	Inc GST
<del>\$110.00</del>	<del>\$126.50</del>
<b>\$87.83</b>	<b>\$101.00</b>

ORDER CODE:	C414
MODEL:	CW-150S
Quantity of Wheels in Pack (No.):	2
Wheel Type:	2 Swivel/Brake
Wheel Diameter (mm):	Ø150
Wheel Width (mm):	50
Total Height to Top of Plate (mm):	~
Load Capacity per Wheel (kg):	450
Load Capacity per Set (kg):	900
Nett Weight (kg):	9



### Description

Industrial quality & 150mm castor wheels, Tyre is made from tough elastic rubber with an load capacity of up to 450kg per castor.

### Features

- Ø150mm x 50mm wide steel wheel with bonded polyurethane
- 2 x swivel wheels with brake
- 450kg each wheel capacity
- Brake also locks wheel from swivelling
- Swivel base incorporates ball bearings
- Ball bearing sealed race on main shaft
- Mounting plate 114 x 102mm with 4 slotted holes

Product Brochure For C414

**Specific Features**



Foot Brake Activated



Foot Brake Released



Top View



Ball Bearings Base with Greasing Nipple



Foot Brake With Swivel Base Lock

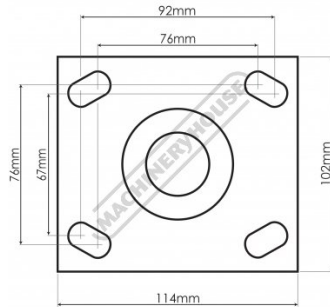

Base Diagram

**Recommended Accessories**

A380  
Steel Work Bench - 3 x Lockable  
Drawers

