

Product Brochure For C7010

## High Precision 3 Jaw Self Centering Lathe Chuck - SK-16

Ø405mm

Front or Rear Back Plate Mount

**On Sale - Special Order**

Ex GST

Inc GST

~~\$5,600.00~~

~~\$6,440.00~~

**\$4,900.00**

**\$5,635.00**



ORDER CODE:	C7010
Model:	SK-16
Chuck Size (mm):	Ø405
Bore / Through Hole Size (mm):	Ø160
Mounting Type:	Back Plate
Gripping Force ((kgf)):	4500
Gripping Range OD (mm):	Ø30 - 380
Gripping Range ID (mm):	Ø110 - 360
Max Speed Rating (rpm):	1500
Nett Weight (Kg):	100

**Strong**



### Description

Auto Strong are one of the world's leading manufacturers of lathe chucks. The SK Series are manufactured in Taiwan with a high precision gripping accuracy of 0.03mm and with a Meehanite casting body they are suitable for high-speed applications.

### Features

- 3 Jaw self centering lathe chuck
- High precision gripping accuracy of 0.03mm (0.0012") T.I.R
- 2 Piece hard jaws could be used as internal jaws and external jaws
- Meehanite chuck body suitable for high speed (Max. 1500rpm)
- Plain back suitable for front or rear back plate mounting
- Optional bolt on soft jaws are available

### Includes

- Chuck key

Product Brochure For C7010

### 3 Jaw Self Centring Precision Lathe Chucks

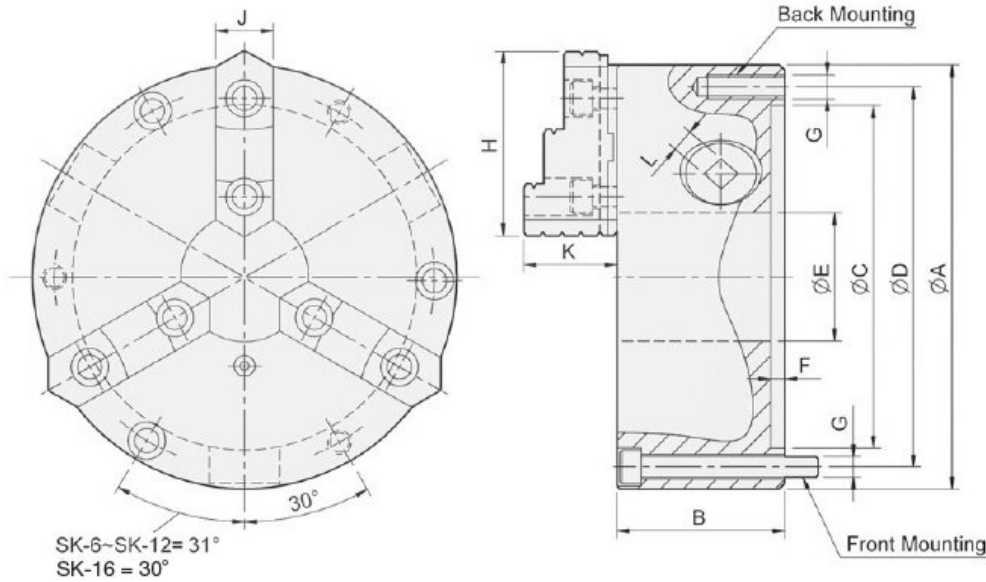

Order Code	Model	A	B	C	D	E	F	G		H	J	K	L	Allowable Handle Torque (kgf•m)	Gripping Force (kgf)	Moment Of Inertial (kg•m <sup>2</sup> )	Max. Speed (r.p.m.)	Weight (kg)	Gripping Range	
								BACK	FRONT										O.D. Range	I.D. Range
C7002	SK-4	112	58	80	95	32	4.8	3-M8	3-M8x65	47	19	31.6	8	4.5	1200	~	2500	3.8	Ø3-Ø95	Ø34-Ø90
C7003	SK-6	167	67	130	147	45	5.5	3-M10	3-M10x70	72	26	40.2	10	9.0	2200	0.03	2000	9	Ø4-Ø160	Ø55-Ø150
C7005	SK-8	200	76.5	160	176	58	5.5	3-M10	3-M10x80	82	28	42	11	11.0	2500	0.07	2000	15.5	Ø8-Ø190	Ø68-Ø180
C7006	SK-9	232	84	190	210	70	6	3-M12	3-M12x90	90.9	32	51.2	12	15.0	3000	0.16	2000	22	Ø11-Ø220	Ø70-Ø210
C7007	SK-10	273	87	230	250	89	8	3-M12	3-M12x90	100.5	35	56.7	12	19.5	4000	0.26	1800	29.7	Ø12-Ø260	Ø80-Ø250
C7008	SK-12	310	96	260	285	105	7	3-M12	3-M12x110	114.5	40	56.8	14	21.0	4200	0.58	1800	43.5	Ø15-Ø300	Ø90-Ø290
C7010	SK-16	405	122	345	375	160	8.7	~	6-M14x130	148.6	50	76.1	15	25.0	4500	1.72	1500	98	Ø30-Ø380	Ø110-Ø360

Product Brochure For C7010

---

**Specific Features**



Optional Soft Jaws

**Recommended Accessories**

C7022  
Soft Jaw Set



C2866  
Chuck Key



L289  
D1-6 Camlock Back Plate



L286  
D1-8 Camlock Back Plate



A358  
Sky Hook Lifting Device



A358A  
Chuck Hook

