

Product Brochure For D185

Pedestal Mill Drill - Geared & Tilting Head - DMF-44

Table Travel: (X) - 480mm (Y) - 200mm (Z) - 850mm

31.5mm Drilling Capacity, Includes Coolant System & Thread Tapping Function

On Sale

| Ex GST | Inc GST |
|-----------------------|-----------------------|
| \$3,892.00 | \$4,475.80 |
| \$3,300.00 | \$3,795.00 |



| | |
|--|---------------|
| ORDER CODE: | D185 |
| MODEL: | DMF-44 |
| Digital Readout: | Optional |
| Type: | Vertical |
| Table Size (mm): | 730 x 210 |
| Column Type: | Ø125mm |
| Spindle Taper - Vertical: | 3MT |
| Spindle Taper - Horizontal: | ~ |
| Longitudinal Travel (X-Axis) (mm): | 480 |
| Cross Travel (Y-Axis) (mm): | 200 |
| Vertical Travel (Z-Axis) (mm): | 850 |
| Type of Slides: | Dovetail |
| Ram Travel (mm): | ~ |
| Spindle to Table (mm): | 630 |
| Spindle to Base: | ~ |
| Spindle Travel / Diameter (mm): | 120 / 75 |
| Throat Depth (max.) (mm): | 280 |
| Tilting Head (Left ~ Right): | ±90° |
| Tilting Head (Forward ~ Back): | Fixed |
| Drilling Capacity (mm): | 31.5 |
| End Milling Capacity (mm): | 28 |
| Face Milling Capacity (mm): | 80 |
| Power Feed - Quill (mm/rev): | ~ |
| Power Feed - Longitudinal (X-Axis) (mm/min): | Optional |
| Power Feed - Cross (Y-Axis) (mm/min): | ~ |
| Power Feed - Vertical (Z-Axis) (mm/min): | ~ |
| Table T-Slot Size (inch / mm): | 14 |
| Work Table Load Capacity (kg): | 55 |
| Spindle Speeds Vertical (No./ rpm): | 6 (95 - 1650) |
| Spindle Speeds Horizontal (No./ rpm): | ~ |
| Spindle Speeds - Universal Head: | ~ |
| Motor Power - Vertical Spindle (kW / hp): | 1.5 / 2 |
| Motor Power - Horizontal Spindle (kW / hp): | ~ |
| Motor Power - Universal Head: | ~ |
| Voltage / Amperage (V / amp): | 240 / 10 |
| Nett Weight (kg): | 390 |

Description

The DMF-44 pedestal milling & drilling machine offers a new dimension of milling capabilities compared to the standard conventional mill drills, as this machine allows you to have a longer job to fit onto the table or even mount your work directly to the machine base for maximum height clearance.

This machine has a tapping function switch to allow you to control the required depth when tapping holes. The milling head also has provisions to adjust up and down in addition to the worktable movement up & down as well, given you the optimum options to best suit your requirements.

The spindle on this machine is a 3 morse taper that is driven by a 2hp, 240V motor via gears in the head to ensure maximum drive without any slippage that can occur & generally inherited with belt drive heads.

Features

Product Brochure For D185

- Ideal for home or light industrial workshop use
- Geared head drill & mill machine with 3 morse taper spindle
- 6 drilling speeds from 95-1650rpm
- Thread tapping function
- Coolant pump system with flexible hose
- Micro down feed adjustment
- Mill head tilts to $\pm 90^\circ$
- Milling table travels 480 x 200mm
- Interlocked spindle safety guard
- Emergency stop switch and overload protection
- Adjustable accurate depth setting for increased productivity
- Rack and pinion wind-up table
- Rack and pinion wind-up drill head
- Thick walled column ensuring greater rigidity
- Concertina slide way cover on y axis
- Adjustable gibs on table
- 14mm T slotted work table and base
- 1.5kW 240V motor

Includes

- Interlocked spindle safety guard
- Face milling cutter with inserts
- 13mm keyed drill chuck and arbor
- Chuck key to suit
- MT3 to MT2 drill sleeve adapter
- Drill drift tool to remove drill chuck or taper shank drills
- M12 x 1.75mm drawbar
- 1/2" x 12TPI drawbar

Specific Features



Tilt Head Full View



Left View



Rear Left View



Rear Right View



Milling Head



Mill Head Close Up



Control Panel with Tapping Function



Geared Spindle Speed Dials

Product Brochure For D185



Adjustable Drilling Depth Stop



Quill Lock Lever

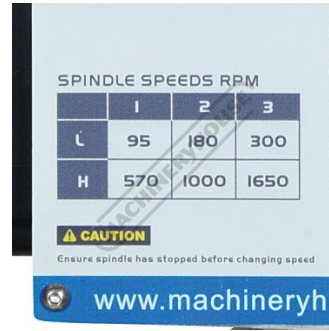

6 Drilling Speeds 95 ~ 165rpm



Interlocked Spindle Safety Guard



Rack & Pinion Wind Up Drill Head



Rack & Pinion Wind Up Table



Quill Handle



Quill Micro Fine Feed Dial



Heavy Duty Motor



Draw Bar For Milling



Table With Coolant Return Hose



Flexible Coolant Hose



Concertina Rear Slide-Way Cover



Tilting Head $\pm 90^\circ$



Head Tilted To 45°



Main Isolation Switch

Product Brochure For D185



Table Cross Feed Handle



Table Longitudinal Handle

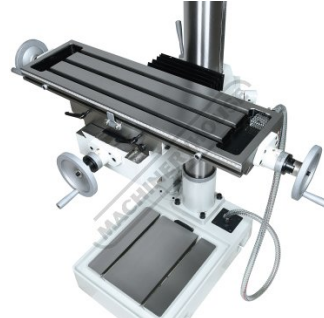

T Slotted Work Table

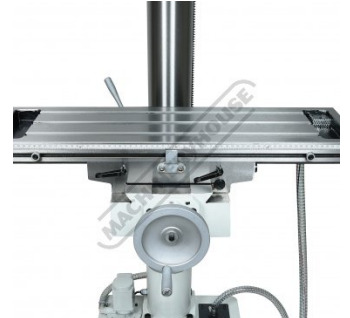

Work Table with Length Stops



T Slotted Base



Coolant Pump System



Coolant Pump



Milling Cutter



Included Parts

Product Brochure For D185

Recommended Accessories

D695
3-Axis Optimum Digital Readout Counter - 1µm



D694
1500mm Optimum Magnetic Digital Readout Scale



M230
Power Feed Unit



M240
Transformer



D322
3MT Morse Taper Shank Drill Bit



K150
Mill-Drill Accessory Package Deal - Imperial Cutters



K151
Mill-Drill Accessory Package Deal - Metric Cutters



C0965
Clamp Kit 58 piece - Workshop Series



Product Brochure For D185

C922B
Collet & Chuck Set - 8 Piece



C926
Collet & Chuck Set - 20 Piece



M3301
Metric HSS Slot Drill & End Mill Set - 10 Piece



M3321
Imperial HSS Slot Drill & End Mill Set - 10 Piece



D1171
Metric Industrial HSS Reduced Shank Drill Set



D1181
Imperial Industrial HSS Reduced Shank Drill Set



D117
Metric HSS Reduced Shank Drill Set



D4433
3MT x JT3 Drill Chuck Arbor - 1/2" BSW Threaded Shank



D4436
3MT x JT6 Drill Chuck Arbor - 1/2" BSW Threaded Shank



C289
Heavy Duty Drill Chuck - Keyed Type



C290
Heavy Duty Drill Chuck - Keyed Type



C292
Industrial Drill Chuck - Keyless Type



Product Brochure For D185

C294
Industrial Drill Chuck - Keyless Type



T004B
Tapping Chuck - Fixed



L300
Magnetic Swarf Remover



S090A
Soluble Metal Cutting Fluid - 1 Litre



S090
Soluble Metal Cutting Fluid - 5 Litre



M9991
Magnetic Floor Sweeper



M800
Rubber Mat - Anti-Fatigue



M805
Rubber Mat - Anti-Fatigue

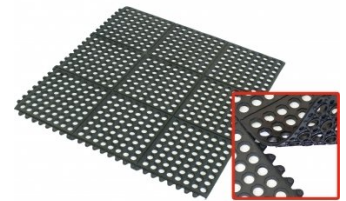

O043
Rust & Corrosion Preventive



O042
General Purpose Lubricant & Corrosion Inhibitor



O044
Rust & Corrosion Preventive

