

## Product Brochure For E040

### 1HP Electric Motor - EM1-14

1440rpm, Ø15.87mm (5/8") Shaft



**On Sale**

Ex GST	Inc GST
<del>\$282.00</del>	<del>\$324.30</del>
<b>\$208.70</b>	<b>\$240.00</b>

ORDER CODE:	E040
MODEL:	EM1-14
Motor Power (kW / hp):	0.75 / 1
Speed (rpm):	1440
Shaft Diameter (mm):	Ø15.87 (5/8")
Reversible Motor (Yes / No):	Yes
Fan Cooled (Yes / No):	Yes
Voltage (V):	240
Amps Required:	10
Input Power Supply Connection:	Includes Plug & Lead



#### Description

Suited for most general applications.

#### Features

- 240V motor
- TEFC - (Totally enclosed fan cooled)
- Reversible motor shaft direction
- Thermal overload with manual reset
- Foot mounted

Product Brochure For E040

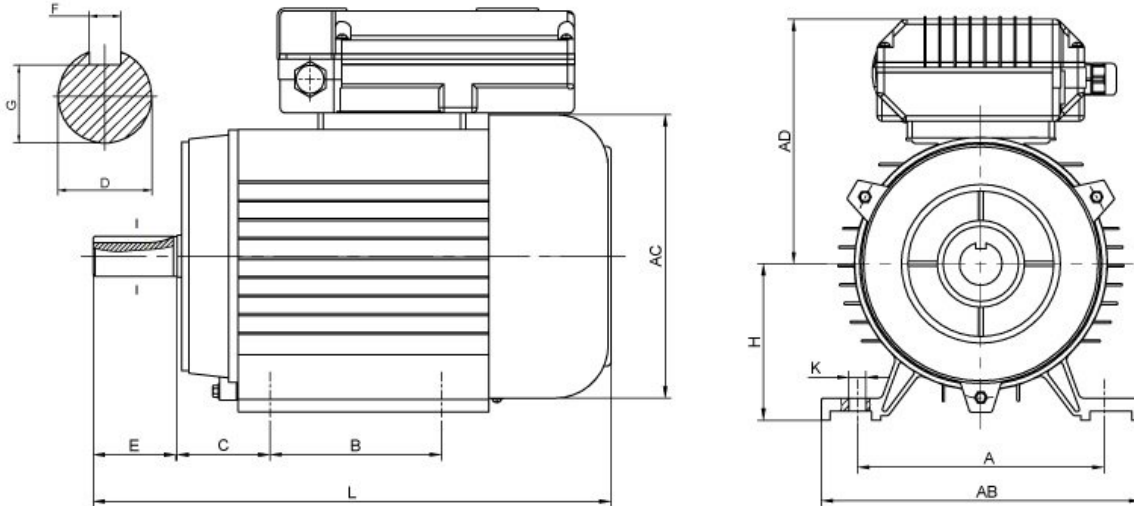

Model	Mounting Dimensions (mm)										Overall Dimensions (mm)			
	A	B	C	D	E	F	G	H	K	AB	AC	AD	L	
<b>EM1-14</b>	125	100	50	15.9	40	4.8	13	80	10	155	156	160	295	
<b>EM25-28</b>	140	100	56	19	50	6	16	90	10	168	174	155	320	
<b>EM2-14</b>	140	125	56	19	50	6	16	90	10	168	174	155	345	
<b>EM3-28</b>	140	125	56	19	50	6	16	90	10	168	174	155	345	

Specific Features



Shown with Lead

SINGLE PHASE INDUCTION MOTOR				CE
FRAME	MEC80	POWER	1HP	
VOLTS	240V/50HZ	AMPS	5.2	
R.P.M.	1440	INS. CLS.	B	
RATING	COMP.	30uF/450V	75uF/300V	
IP54	MANUAL RESET OVERLOAD			
DATE	2012-04			

Specifications