

Product Brochure For E092

## 2HP Electric Motor - EM2-14

1440rpm, Ø19mm Shaft



**On Sale**

Ex GST	Inc GST
<del>\$416.00</del>	<del>\$478.40</del>
<b>\$334.78</b>	<b>\$385.00</b>

ORDER CODE:	E092
MODEL:	EM2-14
Motor Power (kW / hp):	1.5 / 2
Speed (rpm):	1440
Shaft Diameter (mm):	Ø19
Reversible Motor (Yes / No):	Yes
Fan Cooled (Yes / No):	Yes
Voltage (V):	240
Amps Required:	10
Input Power Supply Connection:	Includes Plug & Lead



### Description

Suited for most general applications.

### Features

- 240V motor
- TEFC - (Totally enclosed fan cooled)
- Reversible motor shaft direction
- Thermal overload with manual reset
- Foot mounted

Product Brochure For E092

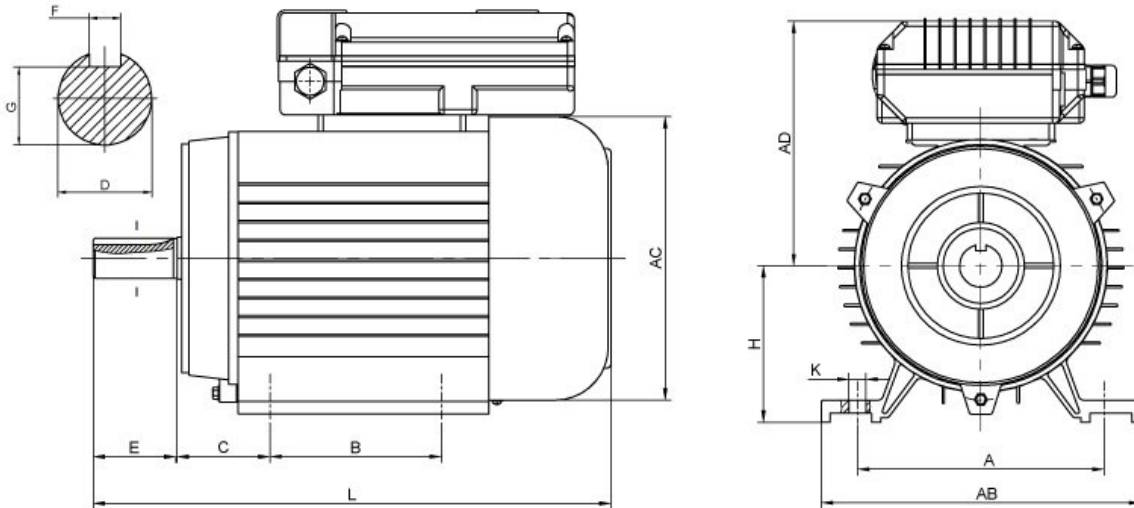

Model	Mounting Dimensions (mm)									Overall Dimensions (mm)			
	A	B	C	D	E	F	G	H	K	AB	AC	AD	L
<b>EM1-14</b>	125	100	50	15.9	40	4.8	13	80	10	155	156	160	295
<b>EM25-28</b>	140	100	56	19	50	6	16	90	10	168	174	155	320
<b>EM2-14</b>	140	125	56	19	50	6	16	90	10	168	174	155	345
<b>EM3-28</b>	140	125	56	19	50	6	16	90	10	168	174	155	345

Specific Features



Shown with Lead

SINGLE PHASE INDUCTION MOTOR				CE
FRAME	MEC90	POWER	2HP	
VOLTS	240V/50HZ	AMPS	8.8	
R.P.M.	1440	INS.CLS.	B	
RATING	COMP.	40uF/450V	150uF/350V	
IP54	MANUAL RESET OVERLOAD			
DATE	2011-09			

Specification