

## Product Brochure For K056

# Hydraulic NC Pressbrake & NC Guillotine Package Deal - PB-70E & HG-840B

Pressbrake 70T x 2500mm, Guillotine 2500 x 4mm

Pressbrake Estun NC-E21 Control, Guillotine Ezy-Set NC-89 Control

### On Sale - Package Deal

Ex GST

Inc GST

**\$53,558.00**    **\$61,591.70**  
**\$44,500.00**    **\$51,175.00**

### Package Contents - SAVE \$11,822.00 (Inc)

1 x S927 - Hydraulic NC Guillotine HG-840B	<b>\$23,080.50</b>
1 x S900GL - Hydraulic NC Pressbrake PB-70E	<b>\$39,916.50</b>

**Normal Price (Inc): \$62,997.00**



METALMASTER



ORDER CODE:	K056
MODEL:	PB-70E & HG-840B
Control Unit (Type):	Estun NC-E21 / Ezy-Set NC-89
Nominal Pressure - Tonnage (Ton):	70
Nominal Pressure - Kilonewtons (kN):	630
Length of Work Table (mm):	2500
Distance Between Columns (mm):	2050
Throat Depth (mm):	260
Maximum Open Height (mm):	325
Ram Stroke (mm):	90
Machine Axis (No.):	2
Safety Guarding System (Type):	Light Curtain System
Backgauge Travel (mm):	520
Table Bed Crowning System (Type):	-
Motor Power (kW / hp):	7.5 / 10
Motor Voltage (V):	415
Floor Space Requirements (L x W x H) (mm):	-
Nett Weight (kg):	7150

## Description

Metalmaster Press brakes are designed and tested to provide precision bending capabilities demanded in industry. The main structural frames are constructed from rolled, stress relieved solid steel to prevent distortion during the bending process and under extreme continuous loads.

Featuring a heavy duty adjustable torsion bar with a positive stop system ensures consistent and accurate bending.

All electrical components are of European quality supplied by leading brands such as Siemens, Schneider, Telemecanique, Merlin Gerin and ABB.

## Features

- PB-70E - Hydraulic NC Pressbrake
- Hydraulic synchronised positive stop design, the ram stroke is controlled by a precision mechanical nut depth stop built into each cylinder, electronically controlled by Estun NC-E21 digital control assuring accuracy and repeatability.
- Mono-block steel frame design, welded, stress relieved and final machining ensures minimal bed deflection under load.
- Bending Parallelism is ensured by the oversize top beam and heavy duty torsion bar.
- Conveniently mounted control box on pendant for quick swivel and adjustments.
- Estun NC-E21 programmable digital control stores up to 40 unique programs with 25 automatic progressive bending steps in each individual program, assuring production accuracy & repeatability every time.
- Estun NC-E21 programmable leadscrew back gauge system, simply enter the desired measurement into the controller and press start, the back gauge then will move quickly into the position you have requested.
- Operator adjustable stroke open height & mute height switches enables increased productivity
- Adjustable bending pressure control allows the operator to quickly and accurately set the pressure required for different material. This user friendly system incorporates hydraulic overload protection.
- European style Intermediate top tool clamping system, featuring an adjustable wedge clamping system for crowning as well as a safety key to stop the punch dropping when changing punch positions.
- Segmented heavy duty 35° offset top punch is segmented for selective bend width applications and offset for return bend clearance.
- Multi vee ('V') bottom die is made from one 2500mm solid die block design to handle heavy plate, safety edge vee ('V') is incorporated in bottom die block.
- Sliding front material sheet supports enabling a wide range of material sizes to be aligned and supported at the required height. This feature is achieved with a "T" slot machined down the total length of the die bed; sheet supports are also adjustable vertically to assist in supporting material with return bends already folded.
- Rear sliding safety gate with micro switch combined with access panels placed at each end of machine allows the operator to clearly view

## Product Brochure For K056

tooling and work piece during the bending operation, Metalmaster specially design gates to suit Australian safety requirements

- The vertical top beam slides are treated to provide greater wear resistance and increased accuracy.
- Mild steel capacity is rated on hot rolled material with 250MPA

- HG-840B - Hydraulic NC Guillotine
- 2500mm x 4mm cutting capacity
- 5.5kW / 7.5hp 415V motor
- Ezy-Set NC-89 Go-To digital display controlled backgauge with DRO counter
- Quick action blade clearance adjustment for shearing material 1 - 4mm
- Hydraulic material clamping for accurate shearing
- One shot lubrication pump & reservoir for slideway protection
- Roving foot pedal control
- Clamp beam design allows clear view to shadow line on material
- Blades made from 9CrSi material suitable for cutting stainless steel
- Plate support tables with transfer balls for quick & easy material alignment and manoeuvrability
- Front sheet supports with ball bearing guides preventing material damage when setting up
- Safety three photo electric light beams on rear guarding
- Safety reset rear guarding button mounted to back of electrical box
- Heavy duty under driven machine construction
- Equipped with shadow line lighting-alignment device
- Mild steel capacity is rated on hot rolled material with 250MPA

- Pre-Commissioning:
  1. Guillotine is run & tested prior delivery
  2. Hydraulic oil is included with machine

### Includes

- PB-70E - Hydraulic NC Pressbrake
- Operated by ESTUN NC- E21 control mounted on a swivel pendant for optimal ergonomics
- LED superior bright work lights provides clearer view to workpiece
- Sliding front sheet support arms
- Emergency stop buttons conveniently located on control panel and foot control
- Mobile dual operation foot control
- Segmented 35° offset top tooling
- Solid one piece four way multi vee (V) die block
- Top tooling tool intermediate holder system with wedge type adjustment
- Powered leadscrew backgauge with 520mm travel, operated by Estun NC-E21 control
- Oil tank level indicator
- Metal constructed safety guarding surrounding machine with clear side viewing panels
- Integrated hydraulic system allowing rapid approach switching automatically to slow bend
- Includes safety control guarding system with light curtains fitted

### Specific Features



PB-70E - Hydraulic NC Pressbrake Right View



Enclosed Rear Safety Guarding



NC Estun E21 Controller



Product Brochure For K056



NC Estun E21

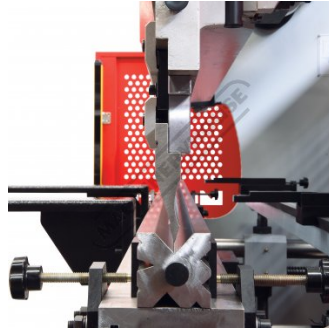

Top And Bottom Tooling



Intermediate Clamps

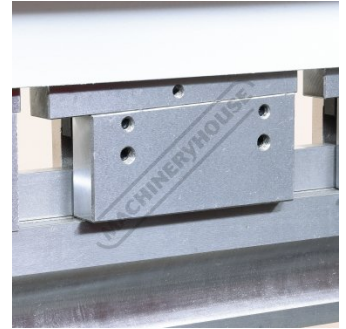

Adjustable Top Tool Taper Wedge System



Adjustable Front Sheet Supports



Tooling Bed Clamps



Safety Guarding



Estun NC E21 Control Ballscrew Backgauge



Estun NC E21 Control Ballscrew Backgauge 2



Backgauge Stops



Synchronised Torsion Bar



Adjustable Pressure Control



Mobile Foot Control

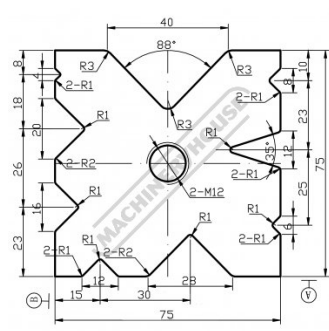

One Piece 4 Sided Die

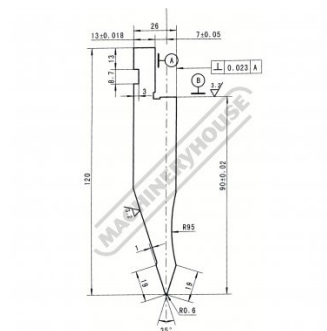

Tooling Top Punch

**Bending Pressures Table**

Values on table are calculated when the steel's tensile strength is 275-450 MPa. If bending sheet metals with different is required, the bending pressure can be obtained in proportion.

Tonnage Calculation Chart

Product Brochure For K056

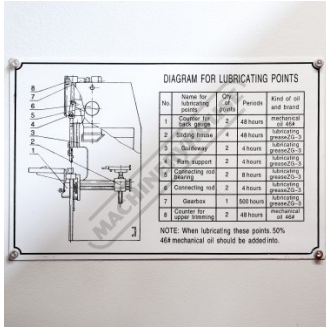

Lubrication Chart



HG 840 Hydraulic NC Guillotine



Left View



Front View



NC 89 Control Panel



NC 89 Backgauge DRO

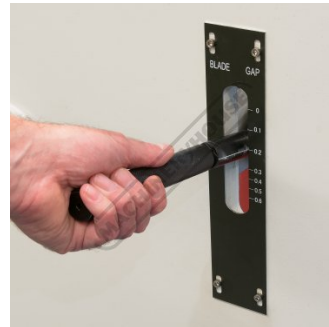

Quick Action Blade Clearance Adjustment Operation



Quick Action Blade Clearance Adjustment Swivel Handle



Quick Action Blade Clearance Adjustment

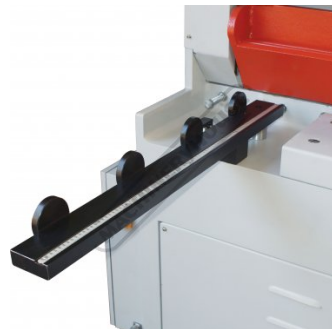

Squaring Arm

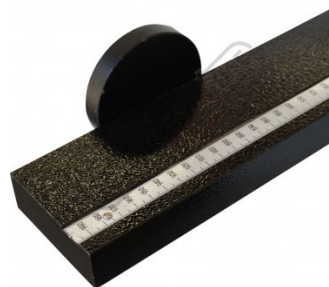

Squaring Arm with Measuring Scale



Front Sheet Supports

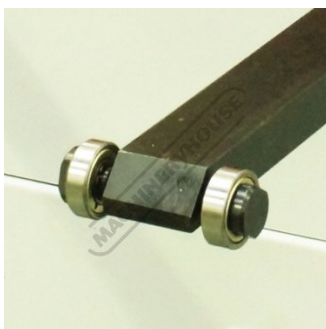

Front Sheet Supports with Roller Bearings



Material Transfer Ball On the Table



3 Safety Photo Sensors



Safety Omron E3ZS Rear Light Sensor Guarding

Product Brochure For K056



NC 89 Control Backgauge



One Shot Lubrication



Micro Switches



Back Gauge Drive Motor



Rear Guard Reset Button



Emergency Stop Switch

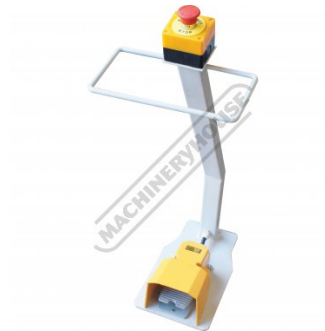

Mobile Foot Control



Shown with Optional Ball Transfer Tables

**Recommended Accessories**

S9927

75mm Die Block Pressbrake Tooling

S989

35° Top Punch Pressbrake Tooling

S996A

60mm Die Block Pressbrake Tooling

S996B

60mm Die Rail Pressbrake Tooling

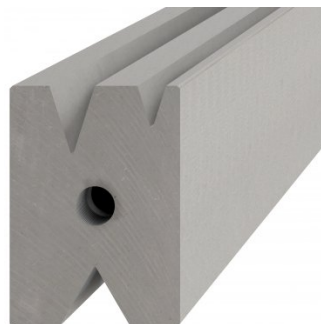
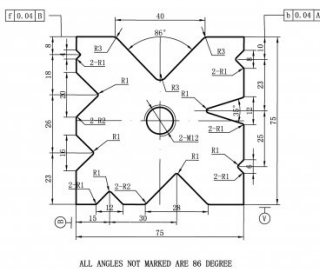

Product Brochure For K056

**S988**  
Quick Action Intermediate  
Clamps



**Q200**  
Combination Set



**Q200A**  
Combination Set



**Q201**  
Universal Bevel Protractor



**Q2105**  
Digital Height Gauge



**M970**  
Digital Angle Rule



**M972**  
Digital Angle Rule



**M974**  
Digital Angle Rule



**M800**  
Rubber Mat - Anti-Fatigue



**M805**  
Rubber Mat - Anti-Fatigue

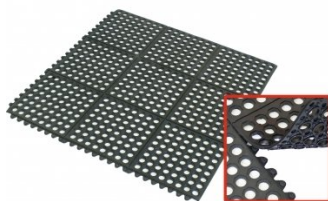

**O043**  
Rust & Corrosion Preventive



**O042**  
General Purpose Lubricant &  
Corrosion Inhibitor



## Product Brochure For K056

---

O044

Rust & Corrosion Preventive

