

Product Brochure For L0519

35° Rhombic Positive Turning Insert - VCMT110304HQ

Grade CA125P - General Purpose Steel
10 Inserts Per Pack

On Sale

Ex GST	Inc GST
\$184.00	\$211.60
\$155.65	\$179.00

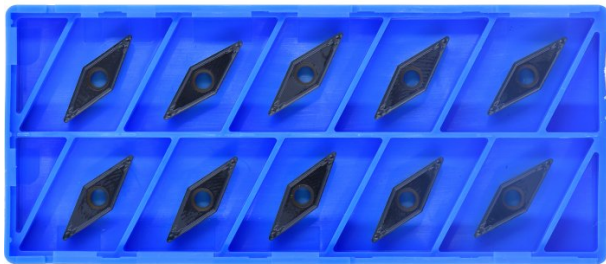

ORDER CODE:	L0519
MODEL:	VCMT110304HQ
Grade:	CA125P
Application:	General Purpose Steel
Pieces in Set (No.):	10
I.C. (mm):	6.35
Thickness (S) (mm):	3.18
Hole Diameter Ø (D1) (mm):	2.75
Corner Radius (RE) (mm):	0.4
Relief Angle (Deg):	7°
d (mm):	~
Insert shape:	~
Use Classification:	~
Clearance Angle:	~

KYOCERA
JAPANESE CARBIDE



Description

CA125P Grade CVD Coated Carbide for Steel
Suitable for continuous to heavy interrupted machining, these inserts are designed for general-purpose applications.

HQ Chipbreaker
General purpose chipbreaker for medium machining.

Features

- Japanese Made
- CVD Coated Carbide with Thin Ultra-fine TiCN Coating
- 10 Inserts Per Pack

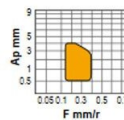
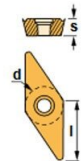

l
11.0 mm

d
6.35 mm

s
3.18 mm

r
0.4 mm

Product Brochure For L0519

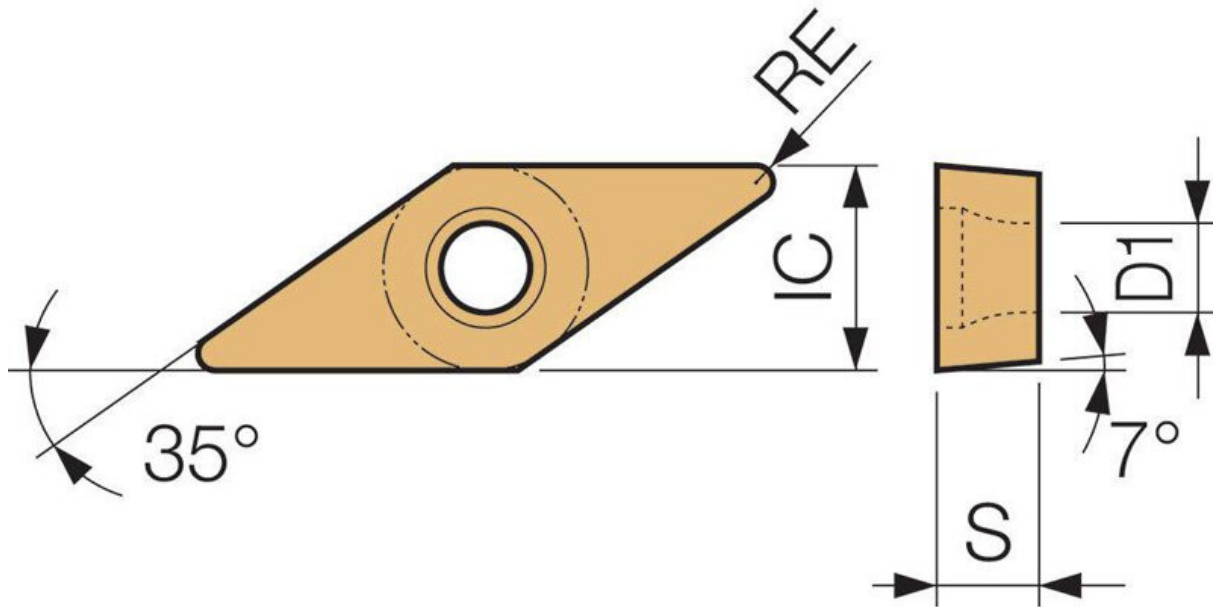

Specific Features



Side View

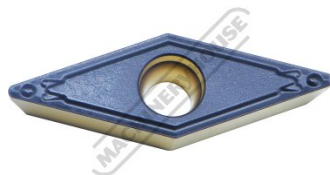

Top View



Bottom View

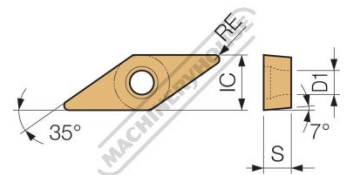

Diagram

Product Brochure For L0519

Recommended Accessories

L4058

93° Rhombic / Positive - Right
Hand Turning Tool Holder

L4060

93° Rhombic / Positive - Right
Hand Turning Tool Holder

