

Product Brochure For L296

Quick Change Toolpost - Model B

230mm Lathe Centre Height



On Sale

Ex GST
\$794.00
\$634.78

Inc GST
\$913.10
\$730.00

ORDER CODE:	L296
MODEL:	B
Lathe Centre Height (mm):	230
Lathe Swing (mm):	460
A (mm):	18
B (mm):	15
C (mm):	100
D (mm):	125
E (mm):	~
H (mm):	47 - 65
h (mm):	85
S (mm):	30
T (mm):	32
Y (mm):	~
Number of Sides (No.):	3
Number of Holders (No.):	5
Nett Weight (kg):	22



Description

Manufactured from carbonized and hardened steel.
Italian design style.

Features

- All bearing surfaces are precision ground to ensure rigidity
- Handy lathe accessory for tool rooms and general engineering shops
- Ease of operation cuts set-up time by 90%
- No shims are required to adjust tools to correct centre height
- Easily fitted to most centre lathes
- Please Note: Some machining required to suit your lathe

Includes

- 4 x Square Tool Holders - for 32mm tools
- 1 x Vee Tool Holders - for boring bars

Optional Accessories

- Holders - L296A

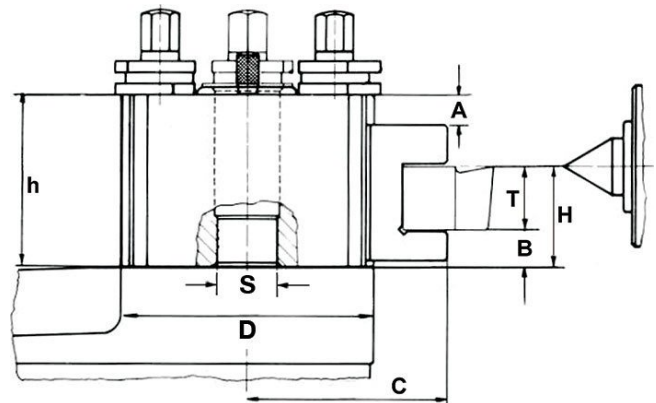

Product Brochure For L296

Recommended Accessories

L296A

Quick Change Toolpost Holder -
Std

L2901

Toolpost T-Handle

L2906

Toolpost Spanner

L634D

Centre Lathe

