

Product Brochure For L297

Quick Change Toolpost - Model C

280mm Lathe Centre Height



On Sale

Ex GST
\$1,038.00
\$830.43

Inc GST
\$1,193.70
\$955.00

| | |
|---------------------------|---------|
| ORDER CODE: | L297 |
| MODEL: | C |
| Lathe Centre Height (mm): | 280 |
| Lathe Swing (mm): | 560 |
| A (mm): | 21 |
| B (mm): | 19 |
| C (mm): | 108 |
| D (mm): | 145 |
| E (mm): | ~ |
| H (mm): | 51 - 72 |
| h (mm): | 94 |
| S (mm): | 38 |
| T (mm): | 32 |
| Y (mm): | ~ |
| Number of Sides (No.): | 3 |
| Number of Holders (No.): | 5 |
| Nett Weight (kg): | 26 |



Description

Manufactured from carbonized and hardened steel.
Italian design style.

Features

- All bearing surfaces are precision ground to ensure rigidity
- Handy lathe accessory for tool rooms and general engineering shops
- Ease of operation cuts set-up time by 90%
- No shims are required to adjust tools to correct centre height
- Easily fitted to most centre lathes
- Please Note: Some machining required to suit your lathe

Includes

- 4 x Square Tool Holders - for 32mm tools
- 1 x Vee Tool Holders - for boring bars

Optional Accessories

- Holders - L297A

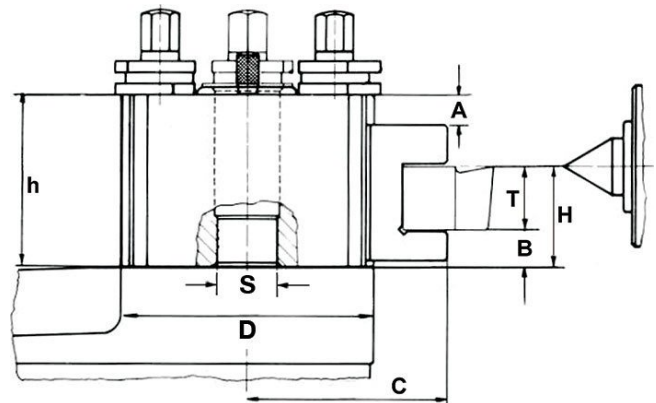

Product Brochure For L297

Recommended Accessories

L297A

Quick Change Toolpost Holder -
Std

L2902

Toolpost T-Handle

