

Product Brochure For M166

NT30-MT3-65 Milling Adaptor



On Sale

Ex GST

\$92.00

\$73.91

Inc GST

\$105.80

\$85.00

ORDER CODE:	M166
MODEL:	NT30-MT3-65
Outer Taper:	NT30
Inside Taper:	MT3
Drawbar Thread (mm / inch):	12mm
L (mm):	65
C (mm):	40
Nett Weight (kg):	0.90

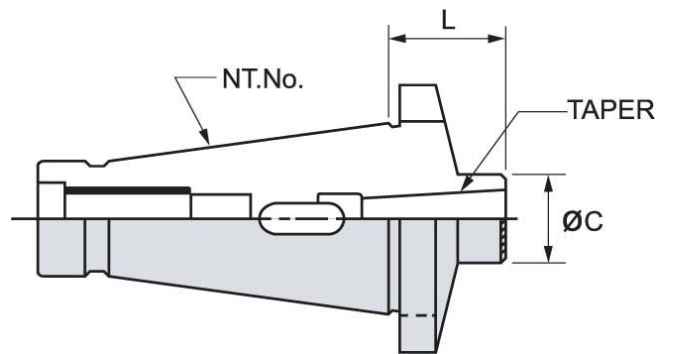

Description

Precision ground and hardened.
Morse taper adaptors are used to adapt a Morse taper tool or cutter to any spindle taper