

Product Brochure For M217

## NT40 Horizontal Milling Attachment - HMA-4105

Suits Ø105 & 86mm Quills

**On Sale - Back In Stock Soon**

Ex GST

Inc GST

**\$1,696.00**

**\$1,950.40**

**\$1,440.87**

**\$1,657.00**

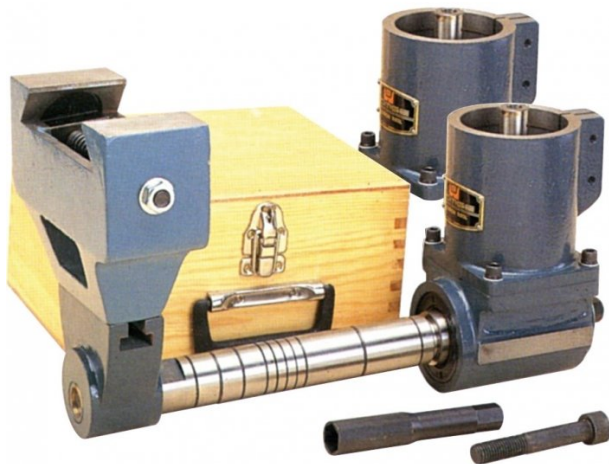

ORDER CODE:	M217
MODEL:	HMA-4105
Taper:	NT40
Quill Diameter (mm):	Ø105 & 86
Maximum Speed (rpm):	2000
A (deg):	50°
B (mm):	140 - 170
C (mm):	181
D (mm):	181
E (mm):	270
F (mm):	230
G (mm):	45
Nett Weight (kg):	34



### Description

Manufactured in Taiwan

Used on vertical milling machine where horizontal work is required. Designed to simplify right angle work without the need for special tooling or complex fixtures.

Note! If using with an air powered drawbar the drive motor of the drawbar needs to be removed as the quill is lowered so that the horizontal attachment can be secured. As the quill is lowered the air drawbar is dis-engaged and cannot be used. For this application use a standard drawbar.

### Features

- Arbor support suits dovetail widths of 140-170mm
- Supplied in deluxe wooden case
- Arbor Ø1" x 12" in length

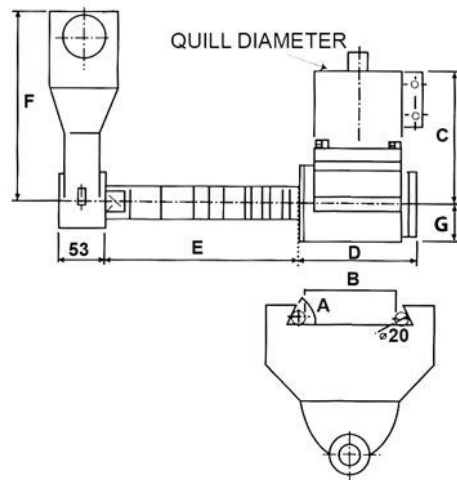

## Product Brochure For M217

---

### Recommended Accessories

M630D

Industrial Turret Milling Machine

