

Product Brochure For M516

Face Mill 45° - Super High-Rake - F45SE12-D63

Ø63mm

Insert tip not included

On Sale

| | |
|---------------------|---------------------|
| Ex GST | Inc GST |
| \$160.00 | \$184.00 |
| \$126.96 | \$146.00 |



| | |
|------------------------------|-------------|
| ORDER CODE: | M516 |
| MODEL: | F45SE12-D63 |
| Cutter Approach Angle (deg): | 45° |
| D (mm): | 63 |
| D1 (mm): | 77 |
| H (mm): | 40 |
| d (lowercase): | 22mm |
| Drawbar Thread: | - |
| Number of Inserts (No.): | 5 |
| Replacement Insert Tips: | (L065) |
| Nett Weight (kg): | 0.95 |



Description

SUPER HIGH-RAKE FACE MILL - 63mm x 45°
Use carbide inserts (ISO) SEKT1204 (L065)
NOTE: Carbide Inserts not included

Features

- Suitable for low horsepower machines where rapid metal removal is required.
- Suitable for steel, cast iron and non-ferrous metals
- Positive rake

Includes

- Lock key for insert

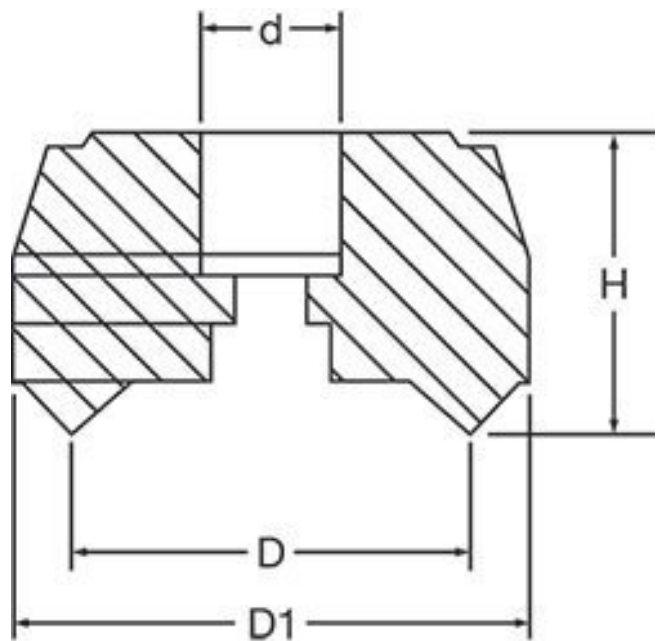

Product Brochure For M516

Recommended Accessories

L065
KYOCERA Carbide Inserts -
Milling



ML090
Cutter Part - Screw



L538
Key to Suit Tool Holder



M562
Face Mill Arbor



M535
Face Mill Arbor



M540
Face Mill Arbor



M550
Face Mill Arbor



T150
BT40-FMB22-45 Face Mill Arbor



Product Brochure For M516

T151

BT40-FMB22-90 Face Mill Arbor

