

## Product Brochure For N013

### Rivet Nut Inserts - M3 x 0.5mm

Aluminium  
Qty 50 In Pack

**On Sale**

Ex GST  
**\$12.00**  
**\$10.17**

Inc GST  
**\$13.80**  
**\$11.70**

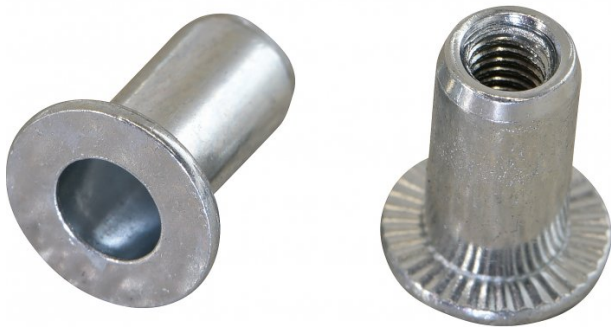

|                                   |                   |
|-----------------------------------|-------------------|
| ORDER CODE:                       | N013              |
| MODEL:                            | ~                 |
| Type:                             | Rivet Nut Inserts |
| Nut Insert Material (Type):       | Aluminium         |
| Quantity in Pack:                 | 50                |
| Rivet Nut Inserts Range (Metric): | ~                 |
| Blind Rivets (mm):                | ~                 |
| Thread Size (T) (Metric):         | M3 x 0.5          |
| Thread Length (TL) (Metric):      | ~                 |
| Length (L) (mm):                  | 9.25              |
| Head Height (HH) (mm):            | 0.75              |
| Head Diameter (HD) (mm):          | 8                 |
| Diameter (D) (mm):                | 4.9               |
| Hole Size (HS) (mm):              | 5                 |
| Grip Range (GR) (mm):             | 0.25 - 2.00       |
| Torque to Turn (Kgf.cm):          | 20                |



#### Description

Suits ATR-10RN Air Operated or RNB40 Twin Handle Nut Riveters

#### Features

- Aluminium inserts
- Fast & easy installation from one side
- Adds a threaded nut to thin sheet metal
- Knurled section under nut head for anti-rotation
- Easy to install
- \*\* NOTE: When used with RNB40 Nut Riveter, the M3 Nut Rivet Mandrel and Adaptor is required, sold separately (Order Code: N0021)

#### Includes

- 50 x Rivet Nut Inserts - M3 x 0.5mm

## NUT INSERT

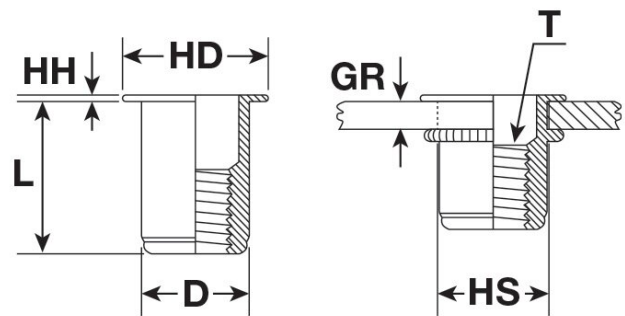

UNINSTALLED

INSTALLED

## Product Brochure For N013

### Specific Features



Packaging Front



Packaging Back

### Recommended Accessories

**N001**  
Nut & Blind Riveter Set - 130  
Piece



**N0021**  
NUT RIVET MANDREL &  
ADAPTOR



**N006**  
Rivet Nut Inserts - M6 x 1.0mm



**N008**  
Rivet Nut Inserts - M8 x 1.25mm



**N010**  
Rivet Nut Inserts - M10 x 1.5mm



**N015**  
Rivet Nut Inserts - M5 x 0.8mm



**N016**  
Rivet Nut Inserts - M6 x 1.0mm



**N018**  
Rivet Nut Inserts - M8 x 1.25mm



## Product Brochure For N013

---

N020

Rivet Nut Inserts - M10 x 1.5mm

