

Product Brochure For N016

## Rivet Nut Inserts - M6 x 1.0mm

Aluminium  
Qty 50 In Pack

**On Sale**

Ex GST  
~~\$16.00~~  
\$13.91

Inc GST  
~~\$18.40~~  
\$16.00



ORDER CODE:	N016
MODEL:	~
Type:	Rivet Nut Inserts
Nut Insert Material (Type):	Aluminium
Quantity in Pack:	50
Rivet Nut Inserts Range (Metric):	~
Blind Rivets (mm):	~
Thread Size (T) (Metric):	M6 x 1.0
Thread Length (TL) (Metric):	~
Length (L) (mm):	13.7
Head Height (HH) (mm):	1.5
Head Diameter (HD) (mm):	12.7
Diameter (D) (mm):	8.9
Hole Size (HS) (mm):	9
Grip Range (GR) (mm):	0.75 - 3.00
Torque to Turn (Kgf.cm):	100



### Description

Suits ATR-10RN Air Operated or RNB40 Twin Handle Nut Riveters

### Features

- Aluminium inserts
- Fast & easy installation from one side
- Adds a threaded nut to thin sheet metal
- Knurled section under nut head for anti-rotation
- Easy to install

### Includes

- 50 x Rivet Nut Inserts - M6 x 1.0mm

## NUT INSERT

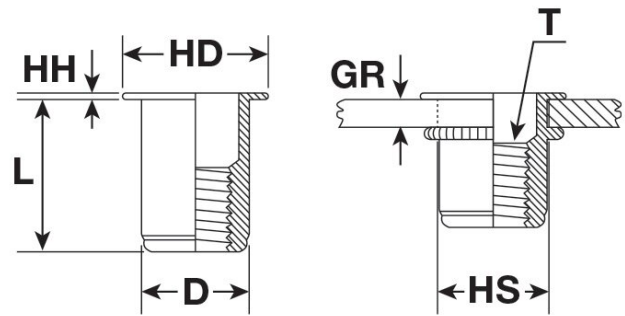

UNINSTALLED

INSTALLED

## Product Brochure For N016

### Specific Features



Packaging Front



Packaging Rear Side

### Recommended Accessories

**N001**  
Nut & Blind Riveter Set - 130  
Piece

**N005**  
Rivet Nut Inserts - M5 x 0.8mm

**N006**  
Rivet Nut Inserts - M6 x 1.0mm

**N008**  
Rivet Nut Inserts - M8 x 1.25mm



**N010**  
Rivet Nut Inserts - M10 x 1.5mm

**N015**  
Rivet Nut Inserts - M5 x 0.8mm

**N018**  
Rivet Nut Inserts - M8 x 1.25mm

**N020**  
Rivet Nut Inserts - M10 x 1.5mm

