

## Product Brochure For P154

# 75T Hydraulic & Pneumatic Press - HPM-75P

Robotic Welded Steel Frame Construction

Includes Adjustable Sliding Cylinder Ram, Pressure Gauge & Bending Vee Blocks

**On Sale - Back In Stock Soon**

Ex GST

Inc GST

~~\$4,502.00~~

~~\$5,177.30~~

**\$4,000.00**

**\$4,600.00**



ORDER CODE:	P154
MODEL:	HPM-75P
Pressing Capacity (Tonne):	75
Hydraulic Ram Operation (Type):	Hydraulic & Pneumatic
Sliding Ram (left-right) (Yes / No):	Yes
Width Between Front Posts (mm):	800
Width Between Side Posts (mm):	215
Table Top Opening - (Front to Back) (mm):	205
Ram To Table (Max.) (mm):	884
Cylinder Stroke (mm):	250
Ram Diameter (mm):	Ø100
Piston Diameter (mm):	~
Minimum Air Flow Rate required (L/Min):	300
Motor Power (kW / hp):	~
Voltage (V):	~
Floor Space (W x D x H) (mm):	1140 x 800 x 1896
Nett Weight (kg):	451

**METALMASTER**



## Description

The Metalmaster HPM-75P 75 tonne press has a variety of uses, ideal for removing and installing bushes, ball joints, bearings, gears, pulleys etc. The HPM-75P is pneumatically or hand operated for easy use and has the added feature of a sliding head which can be moved to the side allowing for those offset pressing jobs.

This 75 tonne press has a fully robotic welded frame for the highest quality, accuracy, and extra rigidity. The hydraulics are assembled in a temperature controlled clean room along with being individually factory tested prior to shipping for maximum reliability & quality. The press is supplied with a pressure gauge, two heavy duty pressing plates, and is fitted with a pneumatic foot pedal, making it ideal for mechanics, farmers or the serious home workshop.

## Features

- Ideal for removing and installing - Bushing, Ball-joints, Bearings, Gears, Pulleys, etc
- Pneumatic or hand operation
- Heavy duty steel construction with robotic fully welded frame
- Adjustable sliding head up to 255mm travel between the vertical post
- Metric / imperial pressure gauge included
- Table height adjustment via a hand operated winch
- NOTE: Minimum Air Flow Rate required is 300 liters/minute

## Includes

- Heavy duty vee blocks

Product Brochure For P154

**Specific Features**



Ram with Removable Cap



Metric Imperial Pressure Gauge



Manual Hydraulic and Pneumatic System



Hydraulic Pump Handle



Pneumatic Foot Pedal



Left View



Dual Purpose Pressing Blocks



Horizontal Sliding Ram

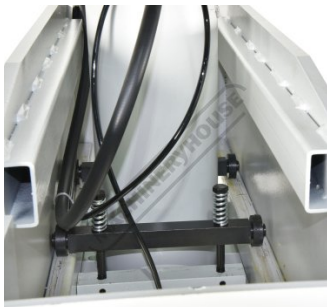

Horizontal Sliding Ram Via Bearings

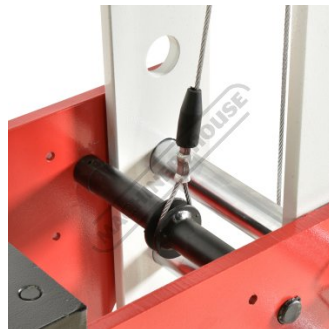

Heavy Duty Table Winch Points



Table Height Adjustment Winch Handle



Table Pins With Safety Clips



Robot Welded Frame

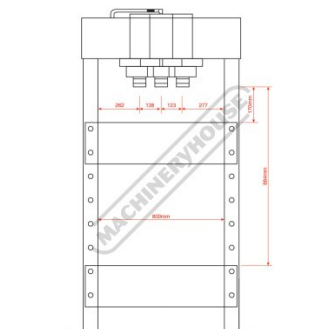

Dimensions

Product Brochure For P154

---

**Recommended Accessories**

P1406  
Hydraulic Press Guard



P030  
Bush Driver Set - 17 piece



P031  
Bearing Race & Seal Driver Set - 10 piece



P1401  
Steel Press Pin Driver Set - 11 piece

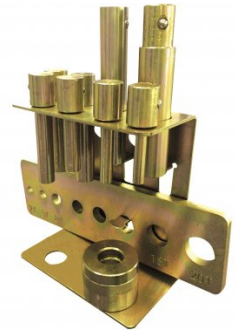

P455  
Pressbrake Attachment - Suits  
Hydraulic Presses

