

## Product Brochure For P9041

# CNC Plasma Cutting Table - Swiftcut PRO 4000WT

4000 x 2000mm Water Table System

Hypertherm Powermax65 SYNC - Cuts up to 16mm Mild Steel Plate

**On Sale**

Ex GST

Inc GST

~~\$70,394.00~~

~~\$80,953.10~~

**\$69,800.00**

**\$80,270.00**



ORDER CODE:	P9041
MODEL:	Swift-Cut PRO 4000WT
Cutting Capacity - Mild Steel (mm):	16
Cutting Table Capacity (mm):	4000 x 2000
Plasma Cutting Unit:	Powermax65 SYNC
Current Output (amp):	20 - 65
Duty Cycle (Typical):	50% @ 65A & 100% @ 46A
Fume Management (Type):	Water Tray System
Cutting Gas (Type):	Air
Plasma Unit Input Voltage (V):	415V
Machine Input voltage:	~
Plasma Unit Input Amperage (amp):	15
Nett Weight (kg):	1300

Swift-Cut  
SMART CUTTING SOLUTIONS



Made in the UK



## Description

With a 4000 x 2000mm cutting area, the Swift-Cut PRO 4000 is a feature packed plasma cutting table with the ability and power to cut for as long as required. With a robust steel fully welded frame and free standing operators console, making it ideal for workshops, metal fabricators, educational establishments, designers and artists.

With gantry parking to allow a full sheet to be loaded overhead and a dropped rail for ease of loading, not to mention the simple on-going maintenance, the Swift-Cut PRO 4000 really is the answer to all your cutting needs.

SOFTWARE: Standard Version

- Auto Arc voltage capture and regulation to automatically adjust the cut settings to suit varied material characteristics
- Program recovery function automates starting part way through a program
- Sheet Trim function to easily trim off excess skeleton
- G code browser & editor for the novice operator
- G code favourites – user customised
- DXF, DWG & JPEG photo import function
- 3D part Viewer
- Advanced importer with ability to re-export and save the filtered DXF
- 5 user assigned reference points for jigs and fixtures
- Sheet rotation function
- Automatic lead in / out of cut paths
- Dry run capability for testing prior to cutting
- Parametric shapes library with over 80 shapes
- Automatic cutting consumable recommendations based on material and thickness
- Manual nesting of parts
- Team viewer software for remote support

SOFTWARE: Advanced Version (Optional Extra)

- All of the Standard version features
- Automatic nesting parts for economical sheet usage
- Automatic Part in part nesting - Nests parts in scrap areas to fully utilise sheet

HYPERTHERM SYNC™ PLASMA:

The Powermax65 SYNC™ is a next-generation professional grade air plasma cutter that dramatically simplifies system operation for cutting. Features automated system process set-up via advanced RFID-enabled SmartSYNC™ torches and a revolutionary single-piece cartridge consumable that provides trackable utilisation data. The Powermax65 SYNC maximizes productivity through reductions in downtime, optimised cut quality performance and streamlined consumable inventory management.

## Product Brochure For P9041

### Features

- Fully fabricated and welded steel frame
- Water tray for efficient control of sparks and fumes with removable stainless steel splash guards for side rail protection
- Dropped rails for ease of loading full sheets
- Gantry parking to allow full sheet to be loaded overhead
- Linear guideways for fast accurate motion
- High speed axis motors with closed loop feedback (encoder) for accuracy and reliability
- Dual motor drive Y-axis
- Rack and pinion drive system
- 360 Degree Breakaway head eliminates damage to torch and improves safety
- Laser guide for easy sheet positioning
- Free-Standing Operators Console with LCD TOUCHSCREEN control
- Cut metal up to 25mm thick depending on the Hypertherm Powermax unit selected
- Soft sense Digital Torch-Height Control (DTHC) Quick response for improved cut quantity and improved torch consumable life. This unique touch sensing is so soft and accurate even the thinnest sheet metal will not deflect while sensing.
- Dynamic Cut Control (DCC) is available on all Swiftcut PRO machines, This feature enables Software control of cutting amps and air pressure, Error messages, air pressures and critical data from the plasma unit is displayed on Swiftcut control screen for operator convenience, On the fly arc voltage, air pressure and cutting speed control ensures the highest quality cut at all times. INDUSTRY 1st UNIQUE TO SWIFT-CUT

### Optional Accessories

- SwiftMark marker unit - Integrated pneumatic marker. Can be used to automatically mark text, fold lines and centre marks on components prior to profiling to avoid costly second operations. Great for part numbering or serial numbering of parts.
- Advanced upgrade - Swiftcam software upgrade

### Specific Features



PRO 4000 Front



Console



Initial Height Sense

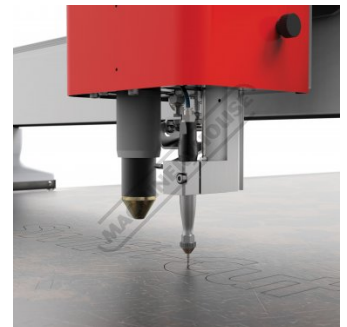

Optional Engraver Shown



Head Gantry



Gantry Safety-Cover



Linear Rail Rack-Side

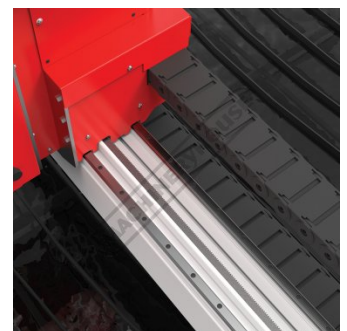

Side Rail Head

Product Brochure For P9041



Cartridge RFID Technology



HYPERTHERM Powermax65 SYNC

**Recommended Accessories**

P9056  
SwiftCAM Advanced Software Upgrade



Software solutions for programming plasma cutting machines

P9064  
Swift-Marker Pro 2020



P799  
Plasma Water Table Fluid



P9065  
Swift-Marker XP Machines



P7870  
Deburring Machine



P8230  
SmartSYNC™ Cartridge Reader

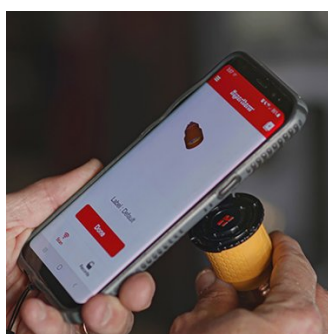

P8231  
SmartSYNC™ Cartridge - FineCut©



P8232  
SmartSYNC™ Cartridge - 45A



Product Brochure For P9041

AP0001  
Air filter element kit -Internal



P8081  
Hypertherm Elimizer Filter -  
Replacement filter element



AP0021  
Hypertherm O-Ring



AP0022  
Hypertherm Contact ring



AP0007  
Hypertherm O-Ring Lube

