

Product Brochure For Q211

## Metric Dial Indicator - 34-211

0-10mm

Smooth movement

**On Sale**

Ex GST

**\$92.00**

**\$73.91**

Inc GST

**\$105.80**

**\$85.00**



ORDER CODE:	Q211
Range (mm / inch):	0 - 10mm
Graduations (mm / inch):	0.01mm
A (mm):	40
B (mm):	21
C (mm):	8
D (mm):	58
E (mm):	19
F (mm):	17
G (mm):	6.35
H (mm):	8



### Features

- Face Ø58mm - Back plate mounting lug
- Smooth movement
- In-out tolerance marker
- Supplied in foam lined plastic case with calibration certificate

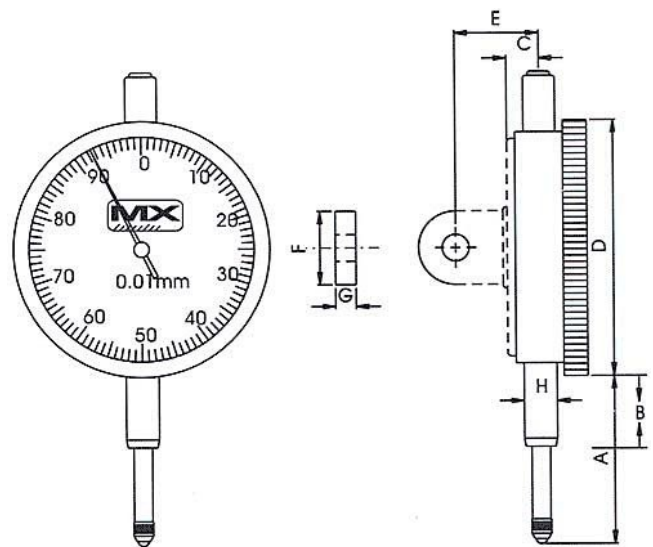

Product Brochure For Q211

---

**Recommended Accessories**

Q2165  
Ø10mm Flat Contact for Dial Indicators



Q2167  
Contact Point for Dial Indicators



Q2125  
Back Plate with Lug for Dial Indicators



M050  
Magnetic Base - Standard



M051  
Magnetic Base - Deluxe - One Lock



Q430  
Magnetic Base - Small



Q435  
Magnetic Base - Large



Q4351  
Magnetic Base - Large



## Product Brochure For Q211

---

Q436

Magnetic Base - One Lock  
(Large)

