

Product Brochure For Q215

## Metric Dial Indicator - 34-215

0-30mm

Smooth movement

**On Sale**

Ex GST

**\$104.00**

**\$82.61**

Inc GST

**\$119.60**

**\$95.00**



ORDER CODE:	Q215
Range (mm / inch):	0 - 30mm
Graduations (mm / inch):	0.01mm
A (mm):	58
B (mm):	21
C (mm):	8
D (mm):	60
E (mm):	20
F (mm):	18
G (mm):	5
H (mm):	8



### Features

- In-out tolerance maker
- Smooth movement
- Flat glass
- Flat back and back lug supplied
- Individual serial numbers with corresponding calibration certificate
- Supplied in foam lined plastic case

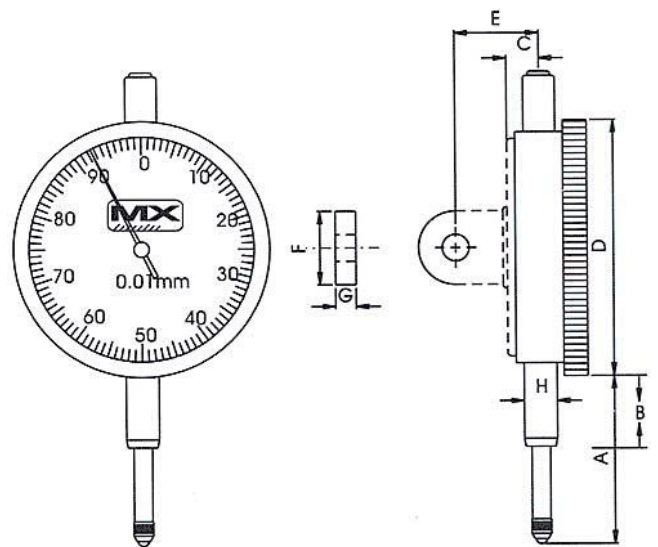

Product Brochure For Q215

---

**Recommended Accessories**

Q2165  
Ø10mm Flat Contact for Dial Indicators



Q2167  
Contact Point for Dial Indicators



Q2125  
Back Plate with Lug for Dial Indicators



M050  
Magnetic Base - Standard



M051  
Magnetic Base - Deluxe - One Lock



Q430  
Magnetic Base - Small



Q435  
Magnetic Base - Large



Q4351  
Magnetic Base - Large



## Product Brochure For Q215

---

Q436

Magnetic Base - One Lock  
(Large)

