

Product Brochure For Q2171

## Dial Test Indicator - Imperial - 34-2171

Jewel Movement - Measuring In Both Directions  
0 - 0.03" Travel

**On Sale**

Ex GST  
**\$110.00**  
**\$87.83**

Inc GST  
**\$126.50**  
**\$101.00**



ORDER CODE:	Q2171
Range:	0 - 0.03"
Graduations:	0.0005"
A (mm):	24.5
B (mm):	17.3
B1 (mm):	~
C (mm):	16.6
D (mm):	Ø31.2
d (mm):	3.95 / 9.5
E (mm):	42.6
F (mm):	38.7
G (mm):	~
H (mm):	~
I (mm):	~
J:	~
K (mm):	~
L (mm):	19
L1 (mm):	~
Ø (mm):	2



### Features

- The dial test indicator is ideally suited for all kinds of comparative measurements in the workshop and inspection room
- It also can be used together with machine tools, apparatus and other measuring devices - Steel ball end
- Jewel movement - measuring in both directions

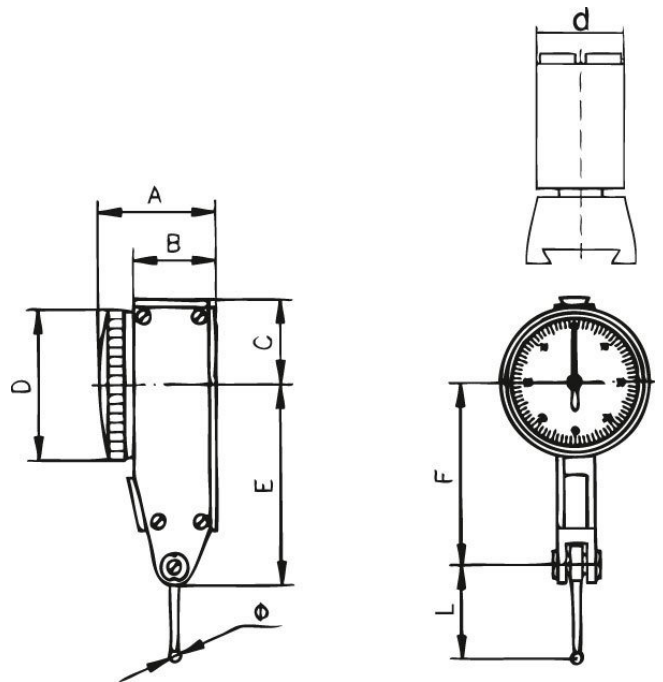

Product Brochure For Q2171

**Specific Features**



Rear Mounting



Front Mounting

**Recommended Accessories**

Q2182  
Stem for Dial Test Indicators

Q2183  
Stem for Dial Test Indicators

Q2184  
Stem for Dial Test Indicators

M050  
Magnetic Base - Standard

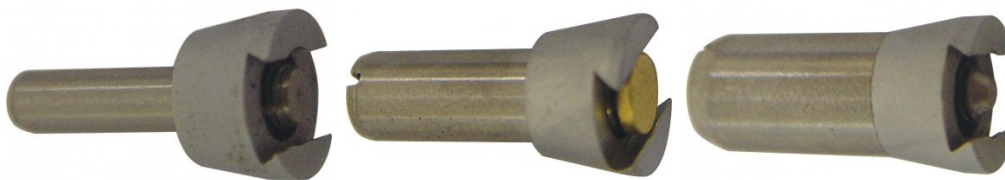

M051  
Magnetic Base - Deluxe - One Lock

Q430  
Magnetic Base - Small

Q435  
Magnetic Base - Large

Q4351  
Magnetic Base - Large



## Product Brochure For Q2171

---

Q436

Magnetic Base - One Lock  
(Large)

