

Product Brochure For Q218

Dial Test Indicator - Metric - 34-218

Gradient of 12 degrees On Dial Face
±1.6mm Travel



On Sale

Ex GST	Inc GST
\$220.00	\$253.00
\$175.65	\$202.00

ORDER CODE:	Q218
Range:	±1.6mm
Graduations:	0.01mm
A (mm):	31.2
B (mm):	~
B1 (mm):	~
C (mm):	~
D (mm):	Ø38
d (mm):	4 / 8
E (mm):	~
F (mm):	~
G (mm):	~
H (mm):	~
I (mm):	16.5
J:	99
K (mm):	~
L (mm):	~
L1 (mm):	19
Ø (mm):	2.5

Product Brochure For Q218

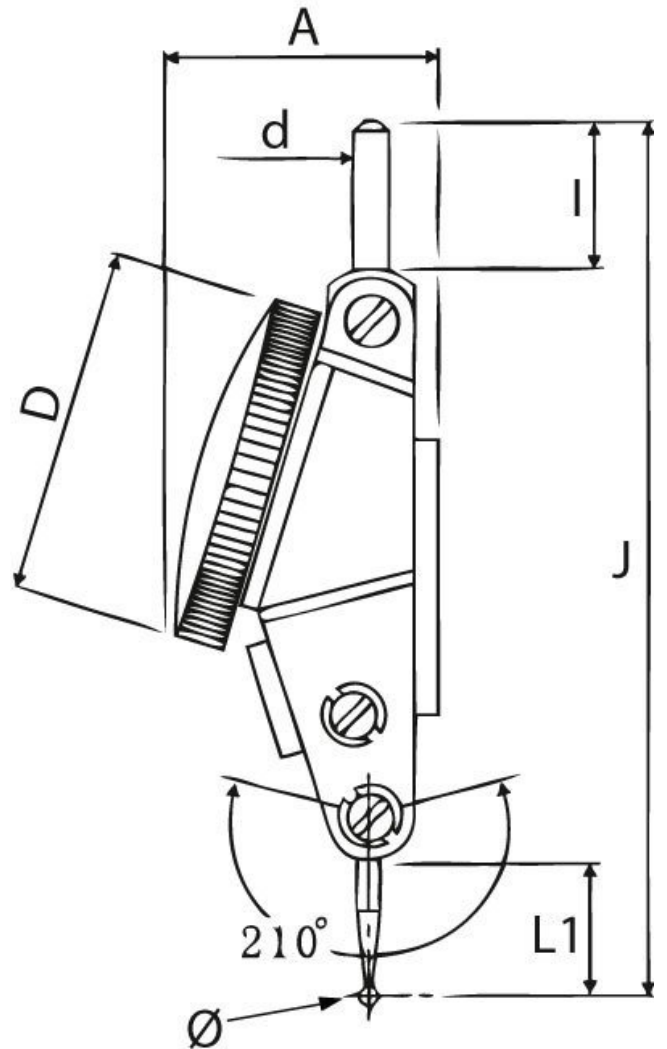

Features

- Large measuring range - 1.6mm - +1.6mm
- Measurement in both directions - steel ball end
- Gradient of 12 degrees on dial face
- Mono enclosure for air tight seal

Product Brochure For Q218

Specific Features



Rear Mounting



Top Mounting

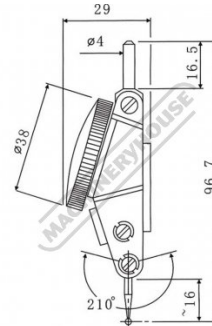

Diagram Dimensions

Recommended Accessories

Q2173
Stylus for Dial Test Indicators

Q2171
Dial Test Indicator - Imperial

Q2182
Stem for Dial Test Indicators

Q2183
Stem for Dial Test Indicators

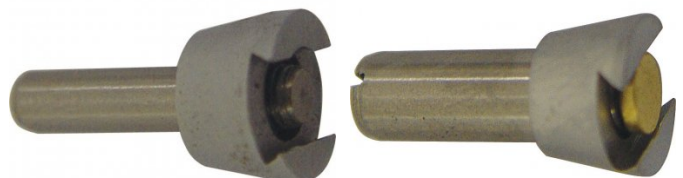

Q2184
Stem for Dial Test Indicators

M050
Magnetic Base - Standard

M051
Magnetic Base - Deluxe - One Lock

Q430
Magnetic Base - Small

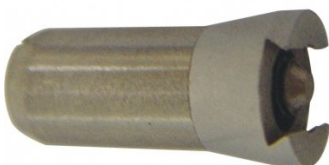

Product Brochure For Q218

Q435
Magnetic Base - Large



Q4351
Magnetic Base - Large



Q436
Magnetic Base - One Lock
(Large)

