

## Product Brochure For T002A

### Reversible Tapping Chuck - K1-MT2

Include 2MT Fixed Arbor

M3 - M6



#### Description

Suits drilling and milling machines.  
Suits all taps M3-M6. Can accept M8 depending on the shank size

#### Features

- Special clutch device permits smooth drive and reverse
- Pre-set depth control minimises possibility of tap breakage
- Cushioned drive prevents thread distortion and cross-threading when tapping in two operations
- Cushioned reverse provides smooth and vibration-free transition between forward and reverse drive

ORDER CODE:	T002A
MODEL:	K1-MT2
Arbor Mount:	Fixed
Taper (MT):	2
Tapping Range (mm):	3 - 6
Tapping Shank Size (mm):	~
D (mm):	65
D1 (mm):	31
L (mm):	195
L1 (mm):	143
A (mm):	51
B (mm):	11
Nett Weight (kg):	1.2

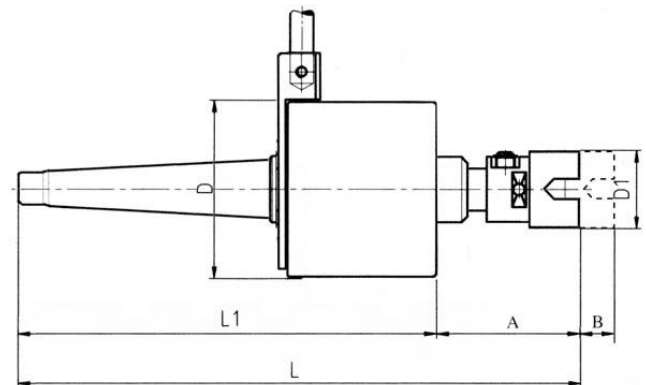

Product Brochure For T002A

---

**Recommended Accessories**

T012

Metric Alloy Steel Tap & Die Set  
- 32 Piece



T013

Metric HSS Tap & Die Set - 32  
Piece



T014

Metric Alloy Steel Tap & Die Set  
- 45 Piece



T015

Imperial Alloy Steel Tap & Die  
Set - 45 Piece



T016

Metric HSS Tap & Die Set - 45  
Piece

