

Product Brochure For T004

## Reversible Tapping Chuck - Adjustable Clutch - T3-MT3

Include 3MT & 4MT Arbours

M5 - M12

**On Sale**

Ex GST

Inc GST

**\$514.00**

**\$591.10**

**\$410.43**

**\$472.00**



ORDER CODE:	T004
MODEL:	T3-MT3
Arbor Mount:	JT6
Taper (MT):	3 & 4
Tapping Range (mm):	5 - 12
Tapping Shank Size (mm):	3.5 - 10
D (mm):	75
D1 (mm):	28
L (mm):	150
L1 (mm):	105
A (mm):	45
B (mm):	12
Nett Weight (kg):	4.2



### Features

- Pre-select torque drive to prevent tap breakage and allow for blind hole tapping
- Tension and compression feature compensates between rate of feed applied and thread pitch
- Suitable for right and left hand, vertical and horizontal tapping
- Fast tap reversal. Re-entry cushioning eliminates cross threading

### Clutch Torque Setting:

- 1 - 5 Nm
- 2 - 20 Nm
- 3 - 50 Nm
- 4 - 75 Nm

### Includes

- MT3 & MT4 x JT6 arbors
- 2 x Collet chuck spanners
- 2 x Rubber flex collets
- 2 x allen keys

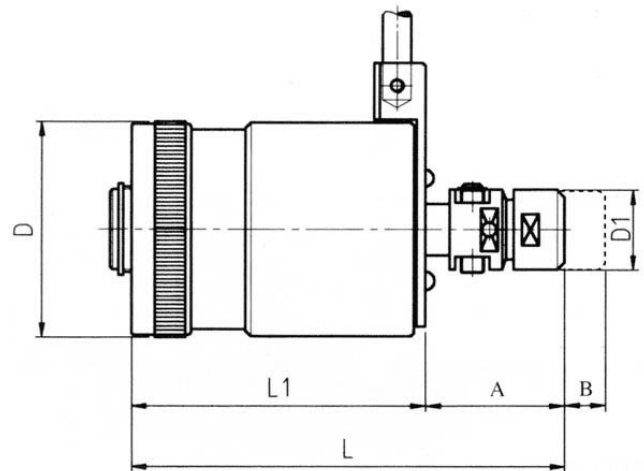

Product Brochure For T004

**Specific Features**



Full Kit



Shown With Tapper



Blow Mold Case

**Recommended Accessories**

T012

Metric Alloy Steel Tap & Die Set  
- 32 Piece



T013

Metric HSS Tap & Die Set - 32  
Piece



T014

Metric Alloy Steel Tap & Die Set  
- 45 Piece



T015

Imperial Alloy Steel Tap & Die  
Set - 45 Piece



T016

Metric HSS Tap & Die Set - 45  
Piece

