

Product Brochure For W07748

BuildPro Levelling Caster - 1 Piece - TMLC600

500kg Load Capacity

On Sale - Back In Stock Soon

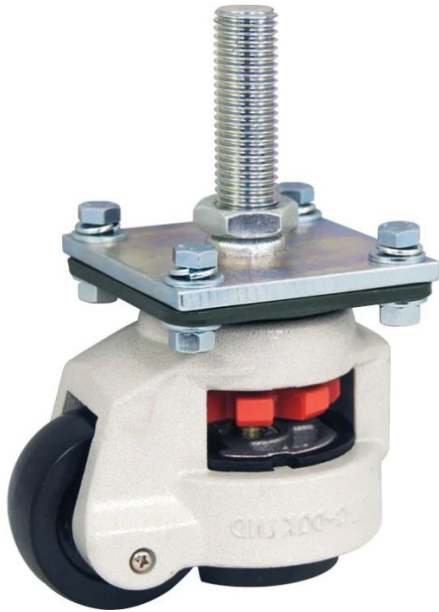

Ex GST

Inc GST

~~\$160.00~~

~~\$184.00~~

\$140.00

\$161.00

ORDER CODE:	W07748
MODEL:	TMLC600
Quantity of Wheels in Pack (No.):	1
Wheel Type:	~
Wheel Diameter (mm):	~
Wheel Width (mm):	~
Total Height to Top of Plate (mm):	~
Load Capacity per Wheel (kg):	~
Load Capacity per Set (kg):	~
Nett Weight (kg):	1.95

BuildPro™



Description

Your BuildPro™ table can be both mobile and fully stationary. These compact, heavy duty levelling casters are the simple way to move and level your BuildPro™ Welding Table. Turn the thumbwheel to lower the wheels and move the table. (Sold individually)

Mobility Caster: Durable caster rolls smoothly on precision ball bearings, with non-marking, non-marring nylon polymer wheels. Dual toe-step braking system can be set for "no-swivel + no-roll". This caster will add 146mm to your total tabletop surface height.

Features

- M20 Thread
- 500kg Load Capacity
- 19mm Maximum height adjustment

Includes

- 1 x TMLC600 Levelling Caster

Product Brochure For W07748

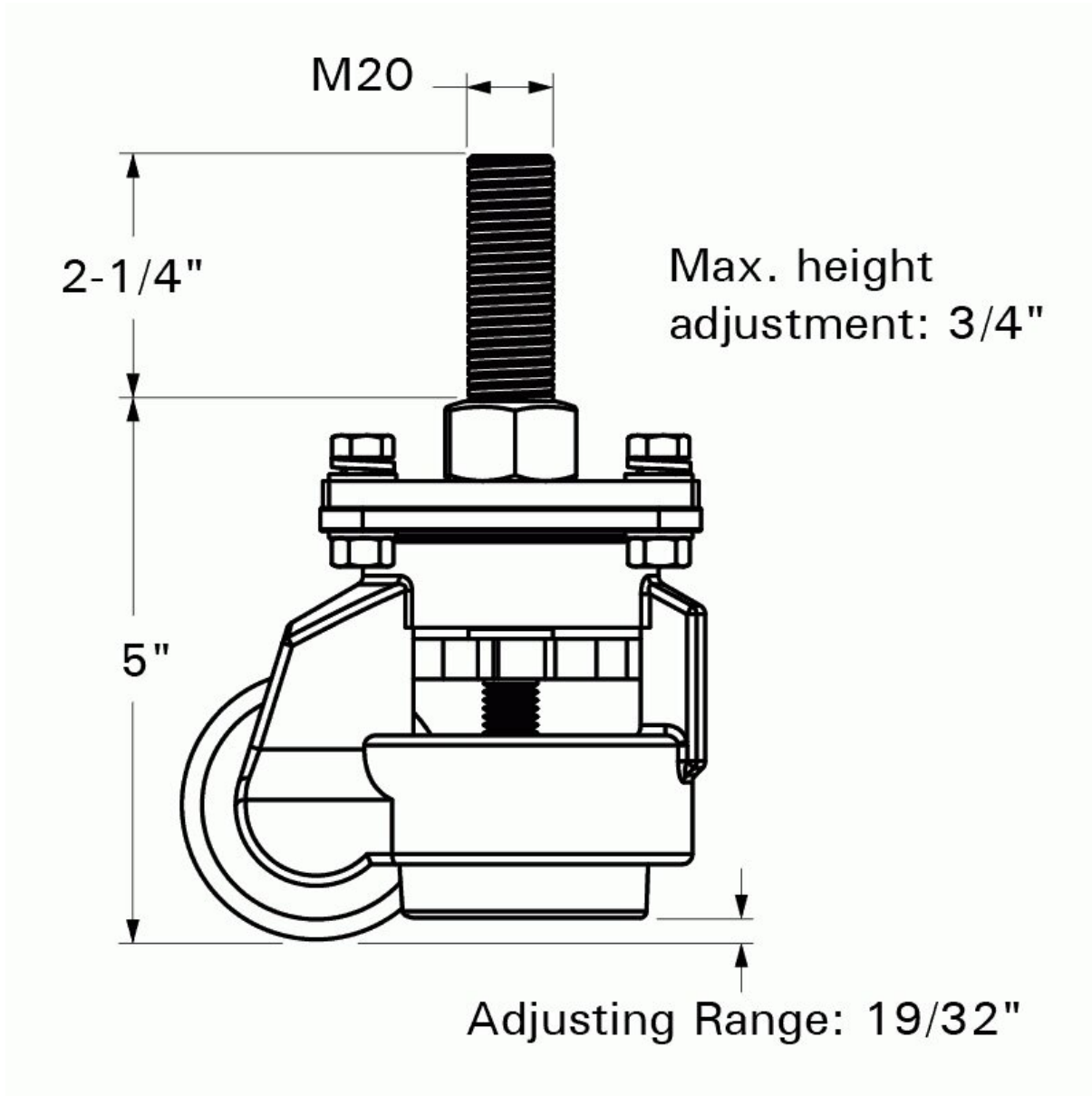

Product Brochure For W07748

Specific Features



Shown on Leg

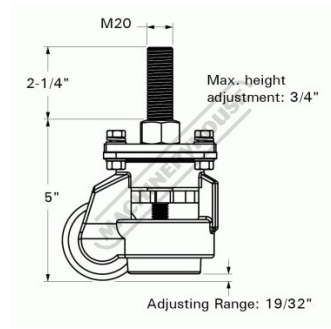

Drawing

Recommended Accessories

W07720A

2560 x 1250mm BuildPro Modular Welding Table - Standard Finish

W07716A

1960 x 1000mm BuildPro Modular Welding Table - Standard Finish

W07749

BuildPro Levelling Pad for Tabletop - 1 Piece

