

Product Brochure For W08012

## BuildPro V-Block Spacer - T64211

Ø38 x 27.5mm

Suits Ø16mm Welding Tables Holes



BuildPro™



### Description

Use the V-Block Spacer to elevate V-Blocks 11.5mm above the tabletop for welding clearance, and for height uniformity when used in combination with Straight Edge Stops.

The very practical, modular design of the BuildPro® Table makes it easy to set-up and tear down for job at hand, big or small. Save time and money by holding, positioning and locating quickly and easily with a wide variety of BuildPro® clamps and accessories.

All BuildPro® Tables have 16mm thick steel plate with Ø16mm holes in a 50mm grid pattern. All tables, except BuildPro® MAX, have 40mm slots between plates.

**On Sale - Limited Stock**

Ex GST

**\$14.00**

**\$5.22**

Inc GST

**\$16.10**

**\$6.00**

ORDER CODE:	W08012
MODEL:	T64211
Suits Table Hole Size (Ø):	16mm
Type:	V-Block Spacer
Suits Table Thickness (mm):	~
Diameter (Ø):	Ø38
Quantity Per Pack (No.):	1
Thread:	~
Over all Height:	27.5mm
Attachment Type:	~
Nett Weight (kg):	~

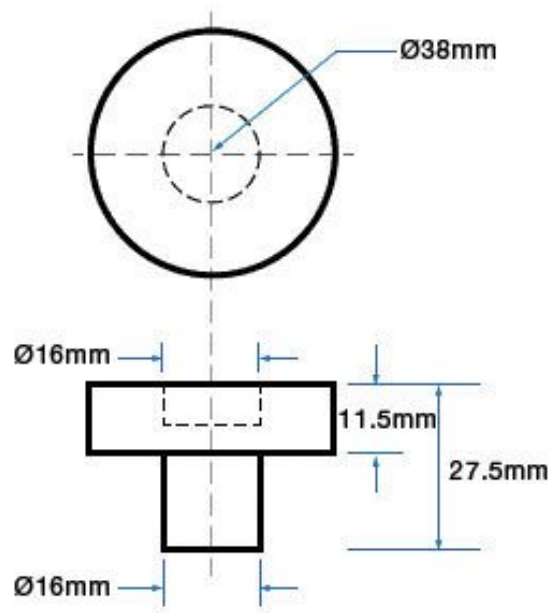

Product Brochure For W08012

---

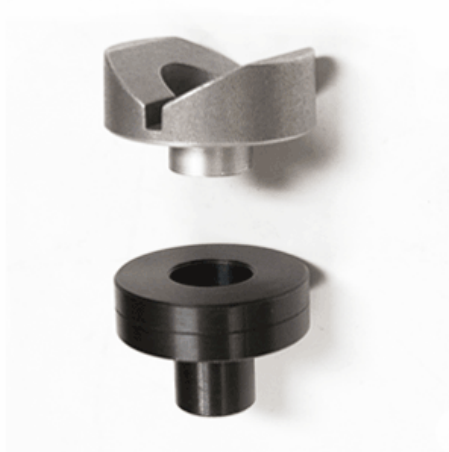

**Specific Features**

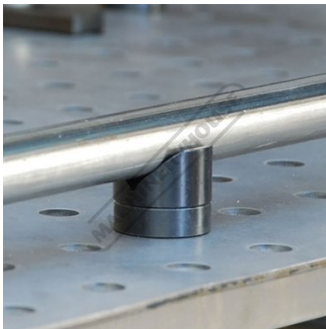

V Block Spacer